



Made in the USA

 **New Holland**  
**Industrial Dryer**  
**K-90 K-90E K-94**  
**OPERATOR'S MANUAL &**  
**SERVICE PARTS CATALOG**



---

# WARRANTY

## New Holland Industrial Dryers

Fanta Equipment Company hereafter called the Company, warrants to the original purchaser of a new New Holland Industrial Dryer from an authorized New Holland Outlet that such equipment is, at the time of delivery to such purchaser, free from defects in material and workmanship and that such equipment will be warranted, if used and serviced in accordance with the recommendations in the Operator's Manual, for a period of one year.

This warranty does not cover normal maintenance and service costs, charges for service calls, and/or transporting equipment to a location where repairs are accomplished, depreciation or damage caused by normal wear.

No warranty shall apply to damage resulting from accident, misapplication, abuse, or failure to follow instructions for operation, maintenance, and storage.

No warranty whatsoever is made on any equipment or part(s) which has been rebuilt, modified, or altered without the consent or knowledge of the Company or if service, other than normal replacement of service items, is performed by someone other than an authorized New Holland Dealer.

Except as set forth above, **THE COMPANY SHALL HAVE NO OBLIGATION OR LIABILITY OF ANY KIND ON ACCOUNT OF ANY OF ITS EQUIPMENT, AND SHALL NOT BE LIABLE FOR SPECIAL OR CONSEQUENTIAL DAMAGES. THE COMPANY MAKES NO OTHER WARRANTY, EXPRESS OR IMPLIED, AND SPECIFICALLY, THE COMPANY DISCLAIMS ANY IMPLIED WARRANTY OF MERCHANTABILITY OF FITNESS. SOME STATES OR PROVINCES DO NOT PERMIT LIMITATIONS OR EXCLUSIONS OF IMPLIED WARRANTIES OR INCIDENTAL OR CONSEQUENTIAL DAMAGES. SO THE LIMITATIONS OR EXCLUSIONS IN THIS WARRANTY MAY NOT APPLY.**

### To the Owner

Fanta Equipment Company is continually striving to improve its products and, therefore, reserves the right to make improvements or changes when it becomes practical and possible to do so, without incurring any obligations to make changes or additions to the equipment sold previously.

---

# OWNER ASSISTANCE

We at Fanta Equipment Company and your New Holland dealer want you to be completely satisfied with your investment. Normally any problems with your equipment will be handled by your dealer's Service Department. Sometimes, however, misunderstanding can occur. If your problem has not been handled to your satisfaction, we suggest the following:

1. Contact the owner or General Manager of the dealership, explain the problem, and request assistance. When additional assistance is needed, your dealer has direct access to our main office
2. If you cannot obtain satisfaction by doing this, contact Fanta Equipment Company's New Holland Dryer Division and provide them with the following:
  - Machine model and serial number
  - Dealership name and address
  - Machine purchase date and amount of use
  - Nature of problem

Fanta Equipment Company  
New Holland Dryer Division  
6521 Storer Avenue  
Cleveland, OH 44102  
Telephone: (216) 281-1515  
Fax Number: (216) 281-7755

When contacting Fanta Equipment Company's New Holland Dryer Division, be aware that your problem will likely be resolved in the dealership using the dealer's facilities, equipment, and personnel. It is important that your initial contact be with the dealer.

---

## TO THE OWNER:

This manual contains information concerning the installation, operation, adjustment, and maintenance of your industrial dryer, chip-wringer, or egg flat dryer. You have purchased a dependable machine, but only by proper care and operation can you expect to receive the performance and long service built into this unit. Please have all operators read this manual carefully and keep it available for ready reference.

This dryer is intended to dry parts, plastic egg flats or separate oils and solvents from metal shavings by spinning with or without the use of optional steam or electric heaters.

Your New Holland dealer will instruct you in the general operation of your unit. Your dealer's staff will be glad to answer any questions that may arise regarding the operation of your unit.

Your New Holland dealer has access to a complete line of genuine New Holland service parts. These parts are manufactured and carefully inspected in the same factories that built the units, to insure high quality and accurate fitting of any necessary replacement parts.



**CAUTION: THIS SYMBOL IS USED THROUGHOUT THIS MANUAL WHENEVER PERSONAL SAFETY IS INVOLVED. TAKE TIME TO READ AND FOLLOW THE INSTRUCTIONS. BE CAREFUL!**

**CAUTION: PICTURES IN THIS MANUAL MAY SHOW PROTECTIVE SHIELDING OPEN OR REMOVED TO BETTER ILLUSTRATE A PARTICULAR FEATURE OR ADJUSTMENT.**

**BE CERTAIN, HOWEVER, TO CLOSE OR REPLACE ALL SHIELDING BEFORE OPERATING THE MACHINE.**

## IMPROVEMENTS

New Holland North America, Inc. is continually striving to improve its products. We reserve the right to make improvements or changes when it becomes practical and possible to do so, without incurring any obligation to make changes or additions to the equipment sold previously.



---

# CONTENTS

SAFETY .....	0-4
SECTION 1 - GENERAL INFORMATION .....	1-1
SECTION 2 - INSTALLATION .....	2-1
SECTION 3 - OPERATION .....	3-1
SECTION 4 - LUBRICATION .....	4-1
SECTION 5 - ADJUSTMENTS AND MAINTENANCE .....	5-1
SECTION 6 - TROUBLESHOOTING .....	6-1
SECTION 7 - SPECIFICATIONS .....	7-1
INDEX .....	7-2

---

# PRECAUTIONARY STATEMENTS

## PERSONAL SAFETY

Throughout this manual and on machine decals, you will find precautionary statements (“CAUTION”, “WARNING”, and “DANGER”) followed by specific instructions. These precautions are intended for the personal safety of you and those working with you. Please take the time to read them.



**CAUTION: THE WORD “CAUTION” IS USED WHERE A SAFE BEHAVIORAL PRACTICE ACCORDING TO OPERATING AND MAINTENANCE INSTRUCTIONS AND COMMON SAFETY PRACTICES WILL PROTECT THE OPERATOR AND OTHERS FROM ACCIDENT INVOLVEMENT.**



**WARNING: THE WORD “WARNING” DENOTES A POTENTIAL OR HIDDEN HAZARD WHICH HAS A POTENTIAL FOR SERIOUS INJURY. IT IS USED TO WARN OPERATORS AND OTHERS TO EXERCISE EVERY APPROPRIATE MEANS TO AVOID A SURPRISE INVOLVEMENT WITH MACHINERY.**



**DANGER: THE WORD “DANGER” DENOTES A FORBIDDEN PRACTICE IN CONNECTION WITH A SERIOUS HAZARD.**

**FAILURE TO FOLLOW THE “CAUTION”, “WARNING”, AND “DANGER” INSTRUCTIONS MAY RESULT IN SERIOUS BODILY INJURY OR DEATH.**

## MACHINE SAFETY

Additional precautionary statements (“ATTENTION” and “IMPORTANT”) are followed by specific instructions. These statements are intended for machine safety.

*ATTENTION: The word “ATTENTION” is used to warn the operator of potential machine damage if a certain procedure is not followed.*

*IMPORTANT: The word “IMPORTANT” is used to inform the reader of something he needs to know to prevent minor machine damage if a certain procedure is not followed.*



## **SAFETY INFORMATION**

**UNSAFE OPERATING PRACTICES AND IMPROPER USE OF THE DRYER ON THE PART OF THE OPERATOR CAN RESULT IN INJURIES OR DAMAGE TO THE DRYER. OBSERVE THE FOLLOWING SAFETY PRECAUTIONS AT ALL TIMES.**

- 1. GIVE COMPLETE AND UNDIVIDED ATTENTION TO THE JOB AT HAND.**
- 2. DRESS APPROPRIATELY - WEAR PROTECTIVE CLOTHING, GLOVES ETC. WHEN JOBS WARRANT.**
- 3. WEAR SUITABLE EYE PROTECTION, GOGGLES ETC.**
- 4. WEAR A SUITABLE HEARING PROTECTIVE DEVICE SUCH AS EARPLUGS IF YOU ARE EXPOSED TO NOISE WHICH YOU FEEL IS UNCOMFORTABLE.**
- 5. FOLLOW LOCAL CODES FOR SAFETY REGULATIONS.**
- 6. UTILIZE EXPERIENCED AND KNOWLEDGEABLE ELECTRICIANS TO CONNECT THE DRYER TO THE POWER SUPPLY.**
- 7. FOLLOW THE LATEST NATIONAL ELECTRICAL CODES AS WELL AS THE APPLICABLE LOCAL CODES.**
- 8. USE OF UNDERWRITERS LABORATORIES APPROVED OR RECOGNIZED COMPONENTS IS HIGHLY RECOMMENDED.**
- 9. INSTALL A DRAIN ADEQUATE IN SIZE AND PROPERLY LOCATED TO CARRY AWAY FLUIDS BEING REJECTED BY THE DRYER.**
- 10. KEEP ALL MECHANICAL OR ELECTRICAL SAFETY DEVICES IN OPERATING CONDITION: DO NOT BYPASS ANY SAFETY DEVICES.**
- 11. AVOID MOVING DRIPPING PARTS OR BASKETS OVER THE ELECTRIC CONTROL BOX AND MOTOR.**
- 12. DO NOT USE THE ELECTRICALLY HEATED DRYERS WHEN WORKING WITH FLAMMABLE MATERIALS.**
- 13. KEEP ALL SHIELDS IN PLACE.**
- 14. DISCONNECT THE POWER TO THE DRYER BEFORE SERVICING THE UNIT.**
- 15. ALWAYS USE PROPERLY SIZED ELECTRICAL PROTECTION DEVICES.**

---

## SAFETY DECALS

The following safety decals have been placed on your machine in the areas indicated. They are intended for the personal safety of you and those working with you. Please take this manual, walk around your machine and note the content and location of these warning signs. Review these decals with your machine operators.

Keep the decals legible. If they are not, obtain replacements from your New Holland dealer.

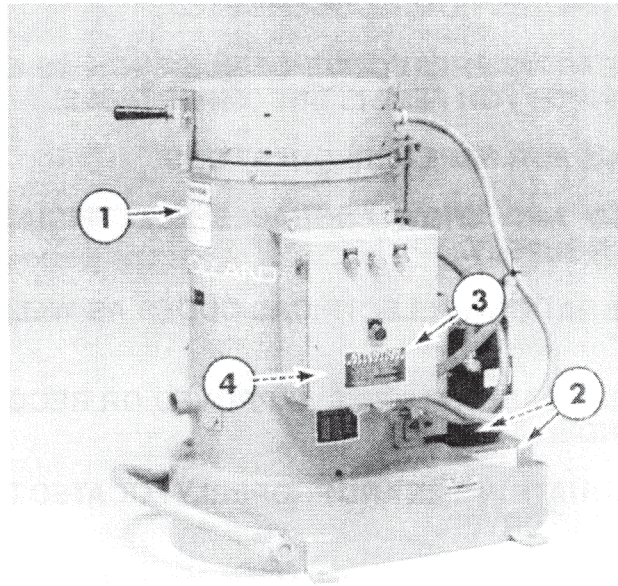

Figure 0-1





## CAUTION

MAX. BASKET LOAD	MODEL K-24	MODEL K-90	MODEL K-94
	75#	150#	250#

USE BRAKE TO HALT FREE SPINNING OF ROTATING COMPONENTS & BASKET. KEEP HANDS, FEET & CLOTHING AWAY FROM POWER DRIVEN PARTS UNTIL ALL ROTATION STOPS.

KEEP ALL GUARDS IN PLACE.

LOCK OUT ELECTRICAL POWER BEFORE REMOVING ANY SHIELDING AND/OR PERFORMING ANY MAINTENANCE OR SERVICE ON THIS MACHINE.

REPLACE ALL SHIELDING BEFORE RESTORATION OF ELECTRICAL POWER.

EXERCISE CARE WITH HEATER ELEMENT AND WITH HEATED LID SURFACES.

M407

855053

1. CAUTION: MAXIMUM BASKET LOAD. USE BRAKE TO STOP DRYER SPINNER. KEEP GUARDS IN PLACE. TURN OFF POWER TO DRYER BEFORE SERVICING.



## WARNING

ROTATING PARTS UNDER THIS COVER MAY CONTINUE TO ROTATE FOR SEVERAL MINUTES AFTER POWER IS SHUT OFF.

LOOK AND LISTEN FOR EVIDENCE OF ROTATION BEFORE REMOVING COVER.

CONTACT WITH THESE ROTATING PARTS MAY CAUSE SERIOUS INJURY.

MDD

9609360

2. WARNING: DO NOT REMOVE SHIELD WITH DRYER RUNNING.

## ATTENTION

MOTOR OVERLOAD OR ABUSE WILL TRIP THIS MACHINE'S PROTECTIVE CIRCUIT. DO NOT RESTART UNTIL CAUSE OF OVERLOAD HAS BEEN DETERMINED AND CORRECTED.

TO RESTART: WAIT 30 TO 45 SECONDS, THEN DEPRESS "START" BUTTON.

M405

719836

3. ATTENTION: MOTOR OVERLOAD OR ABUSE WILL TRIP THIS MACHINE'S PROTECTIVE CIRCUIT.



## WARNING

IT IS THE PURCHASER'S RESPONSIBILITY TO ENSURE THAT THIS EQUIPMENT IS PROPERLY LOCATED, WIRED, INSTALLED, AND OPERATED IN FULL COMPLIANCE WITH ALL APPLICABLE ELECTRICAL CODES. UTILIZE ONLY EXPERIENCED AND KNOWLEDGEABLE ELECTRICIANS, AND BE SURE THEY CONSULT THE OPERATOR'S MANUAL.

M405

782166

4. WARNING: INSTALL DRYER FOLLOWING APPLICABLE ELECTRICAL CODES AND EXPERIENCED AND KNOWLEDGEABLE ELECTRICIANS. LOCATED ON INSIDE OF CONTROL PANEL COVER.



---

# SECTION 1

## GENERAL INFORMATION

### K-24 DRYER

With the New Holland Model K-24 industrial centrifugal dryer, you can thoroughly dry parts in basket loads weighing up to 75 lbs. (34 kg) in as little as 15 seconds. This is obtained from both air-drying and spin-drying at 825 RPM. Heavy-duty 12" x 12" (305 mm x 305 mm) baskets are used to handle the parts.

One person can easily operate the dryer with full efficiency and safety in five square feet of floor space. You can expect years of clean, quiet-running operation from your centrifugal dryer with proper installation and regular maintenance.

The optional 1-1/4" exhaust is shown at 1. This exhaust is not recommended for use with plastic baskets when electric heat is in operation.

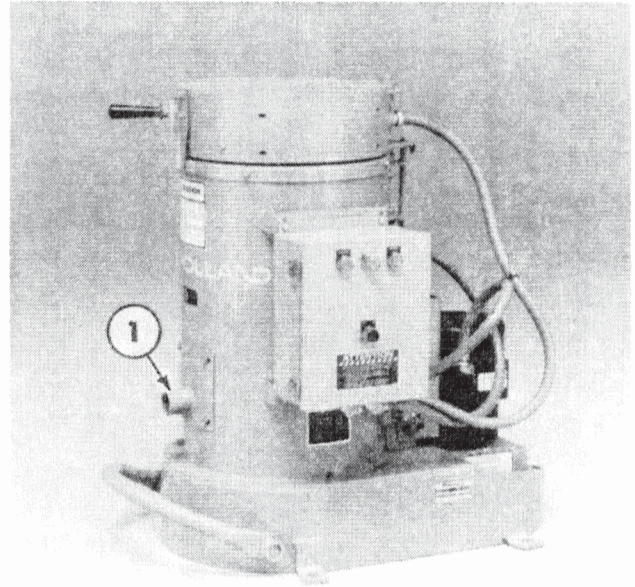

Figure 1-1

### K-90 DRYER

With the New Holland Model K-90 industrial centrifugal dryer, you can thoroughly dry parts in basket loads weighing up to 150 lbs. (68 kg) in as little as 15 seconds. This is obtained from both air-drying and spin-drying at 625 RPM. Heavy-duty 18" x 18" (457 mm x 457 mm) baskets are used to handle the parts.

One person can easily operate the dryer with full efficiency and safety in nine square feet of floor space. You can expect years of clean, quiet-running operation from your centrifugal dryer with proper installation and regular maintenance.

The standard 4" exhaust is shown at 1.

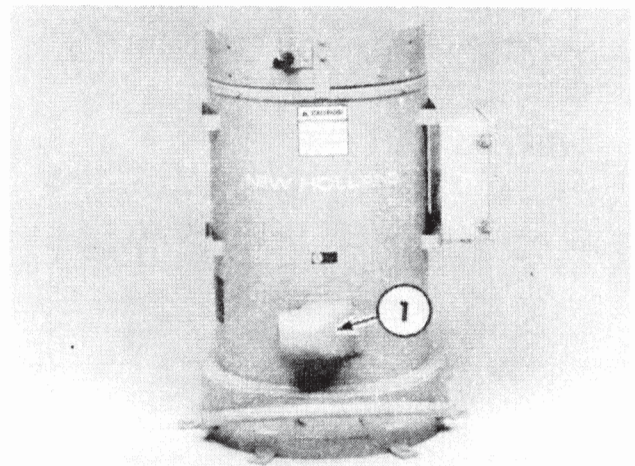

Figure 1-2



### K-90E DRYER

With the New Holland Model K-90E egg flat dryer you can quickly and efficiently dry the plastic egg flats now used in great quantity by the egg industry. Using this dryer, up to 100 flats at a time can be removed from an adjacent flats washer and dried in approximately 15 seconds. Actual drying time will vary, depending on wash temperature, amount and type of detergent used, and efficiency of rinse by the washer. Its compact size permits convenient location close to the flats washer.

At 100 flats per drying cycle and a conservative one minute cycle time, the New Holland K-90E dryer will dry 6,000 flats per hour or the flats from 500 cases per hour, more than sufficient to stay ahead of several egg flat washers.

One person can easily operate the dryer with full efficiency and safety in nine square feet of floor space. You can expect years of clean, quiet-running operation from your centrifugal dryer with proper installation and regular maintenance.

The 1-1/4" exhaust shown at 1, is standard on egg flat dryers. The optional 4" exhaust may be installed.

### K-94 DRYER

With the New Holland Model K-94 industrial centrifugal dryer, you can thoroughly dry parts in basket loads weighing up to 250 lbs. (113 kg) in as little as 15 seconds. This is obtained from both air-drying and spin-drying at 625 RPM. Heavy-duty 18" x 24" (457 mm x 609 mm) baskets are used to handle the parts.

One person can easily operate the dryer with full efficiency and safety in nine square feet of floor space. You can expect years of clean, quiet-running operation from your centrifugal dryer with proper installation and regular maintenance.

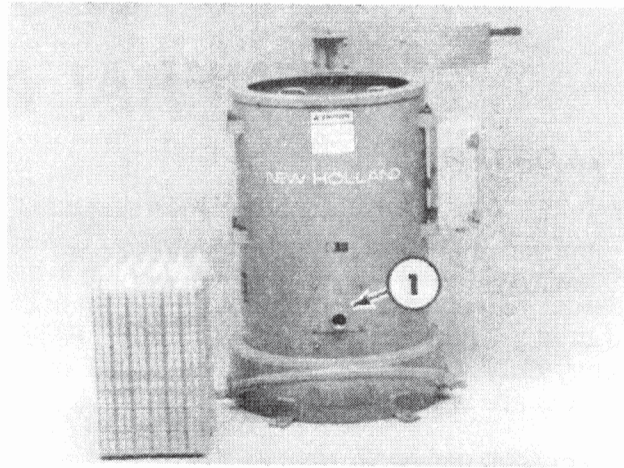

Figure 1-3

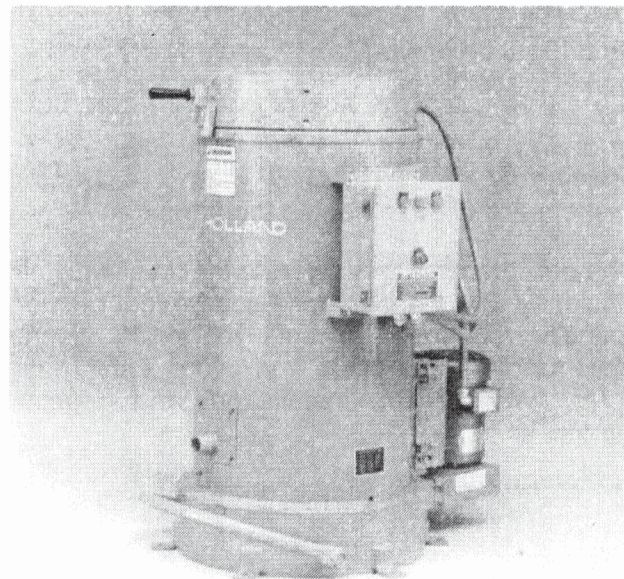

Figure 1-4



### CHIP-WRINGERS K-24, K-90, K-94

The models K-24 (shown), K-90, and K-94 industrial dryers can be built in a chip-wringer configuration and can be used to reclaim cutting oils from metal chips or shavings produced by screw machines, boring mills, grinders and other machining operations.

The New Holland Chip-wringers use centrifugal force to spin cutting oil from a basket of chips. Simultaneously, a turbine fan mounted below the basket pulls a powerful stream of air down through the parts load, then blows the coolant off the chips and toward the dryer drain.

In seconds, you get reusable oil and dry, salable chips.

The New Holland Chip-wringers are available in 75, 150, and 250 pound capacities to meet different shop requirements.

The 1-1/4" exhaust shown at 1, is standard on chip-wringer models.

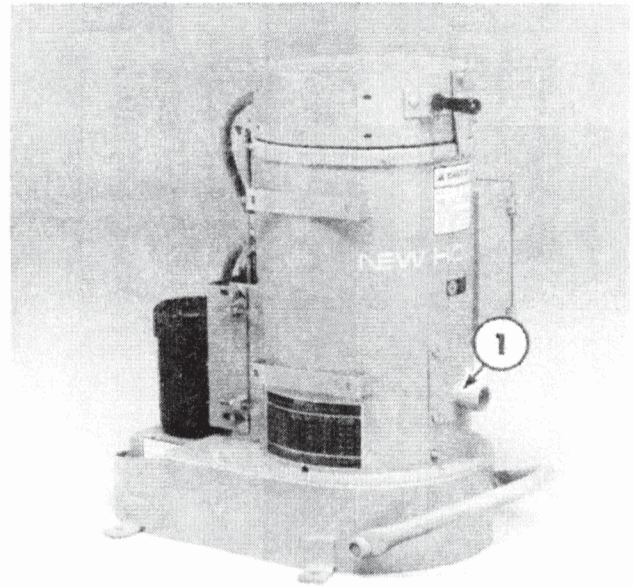

Figure 1-5



---

# SECTION 2

## INSTALLATION

The Models K-24, K-90, K-90E, and K-94 dryers and chip-wringers should be bolted to an I beam frame imbedded in concrete with 5/8" (16mm) Grade 5 hex-head bolts. Proper mounting of the dryer/chip-wringer will prevent vibration and future mounting bolt failures.

Be sure the dryer/chip-wringer is located for operational convenience and for trouble free operation. The following are recommendations for locating the dryer for safe and satisfactory operation.

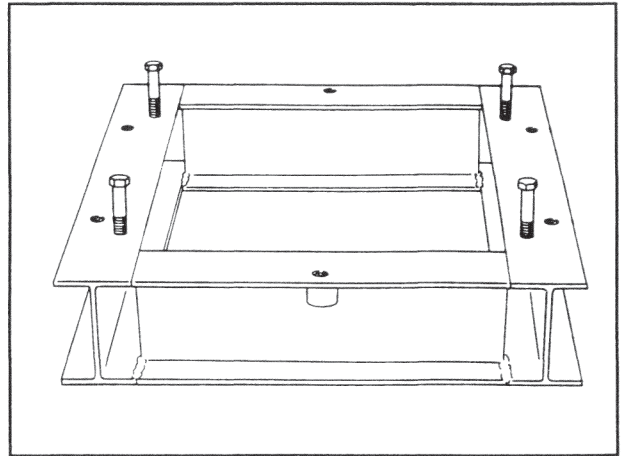

Figure 2-1

### DRYER LOCATION

Recommended wall clearance:

Nonflammable wall surface

Model K-24 minimum 24" (610 mm).

Model K-90, K-90E, K-94 minimum 30"  
(762 mm).

Flammable wall surface

Model K-24 minimum 42" (1067 mm).

Model K-90, K-90E, K-94 minimum 48"  
(1219 mm).

**NOTE: Flammable wall surface is with electric heat lid only.**

**NOTE: Refer to your local codes for regulations and requirements for Flammable and Non-Flammable clearances.**

### K-24 INSTALLATION

Clearances for proper lid operation and floor mounting for K-24.

- A Dryer center line to end of handle, 21-1/4" (540 mm).
- B Dryer center line to control box, 15" (381 mm).
- C Anchor tabs, 18-1/4" (464 mm).
- D Anchor tabs, 21-1/2" (546 mm).
- E Dryer center line to center line anchor tabs, 10-3/4" (273 mm).

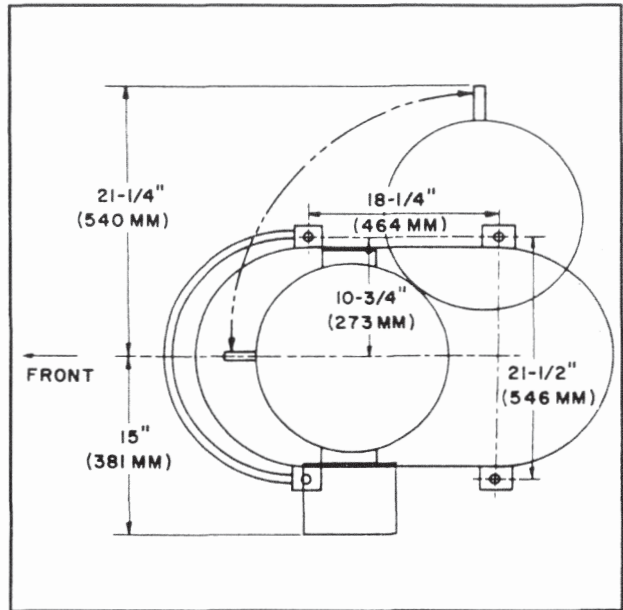

Figure 2-2

Base unit height and length for K-24.

- A Wall clearance (minimum, refer to codes).
- B Dryer load height, 30-1/2" (775 mm)
- C Overall height, 36-1/2" (927 mm)
- D Center of dryer to front, 15-1/4" (387 mm)
- E Center of dryer to rear, 22-3/4" (578 mm)

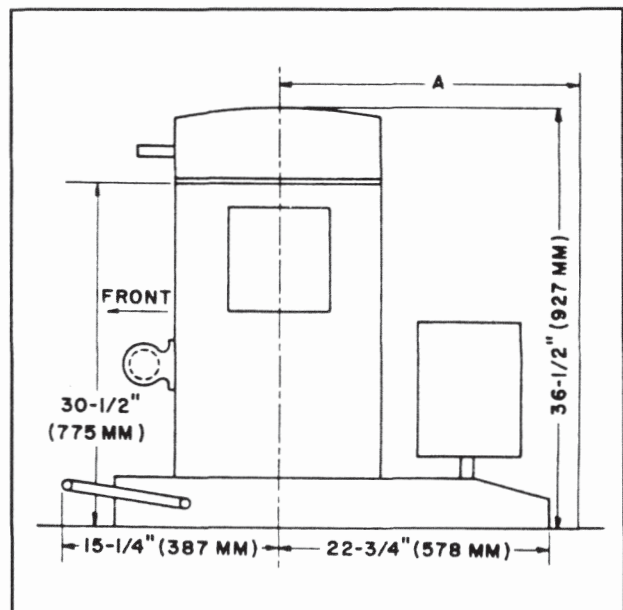

Figure 2-3

### K-90, K-90E, K-94 INSTALLATION

Clearances for proper lid operation and floor mounting for the K-90, K-90E, and K-94.

- A Dryer center line to end of handle, 27-1/4" (692 mm)
- B Dryer center line to control box, 20" (508 mm)
- C Anchor locations - sides of dryer, 28-1/4" (718 mm)
- D Dryer center line to side anchors, 14-1/8" (359 mm)
- E Dryer center line to front and rear anchors, 7-3/32" (180 mm)
- F Front and rear anchors location, 14-3/16" (360 mm)
- G Front anchor center to rear anchor center, 24-1/2" (622 mm)
- H Side anchor center to front and rear anchor center, 12-1/4" (311 mm)

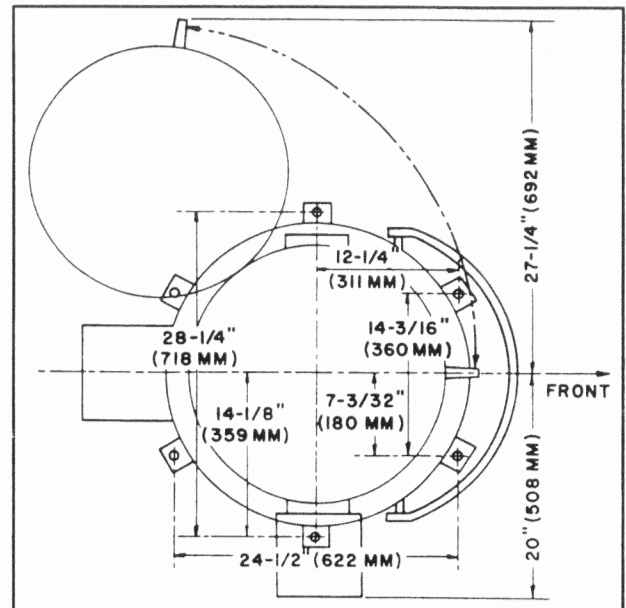

Figure 2-4

Base unit height and length for K-90, K-90E.

- A Wall clearance (minimum, refer to codes).
- B Dryer load height, 37" (940 mm)
- C Overall height, 40-1/2" (1029 mm)
- D Center of dryer to front, 18" (457 mm)
- E Center of dryer to rear, 23" (584 mm)

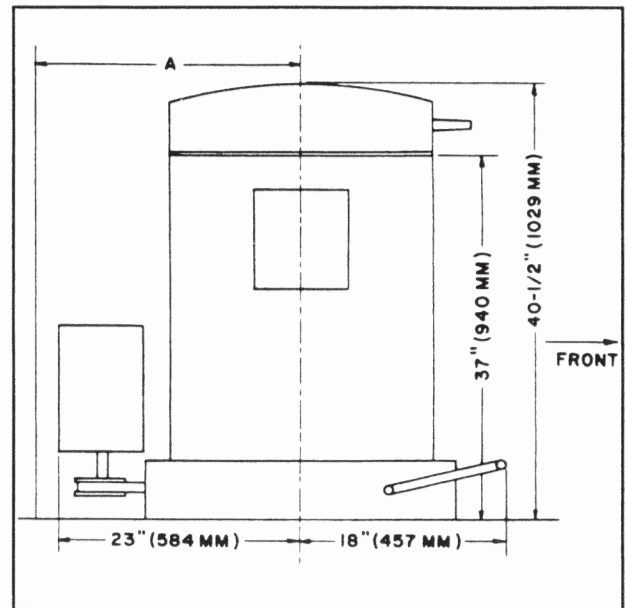

Figure 2-5



## INSTALLATION

Base unit height and length for K-94.

- A Wall clearance (minimum, refer to codes).
- B Dryer load height, 43" (1092 mm)
- C Overall height, 46-1/2" (1181 mm)
- D Center of dryer to front, 18" (457 mm)
- E Center of dryer to rear, 23" (584 mm)

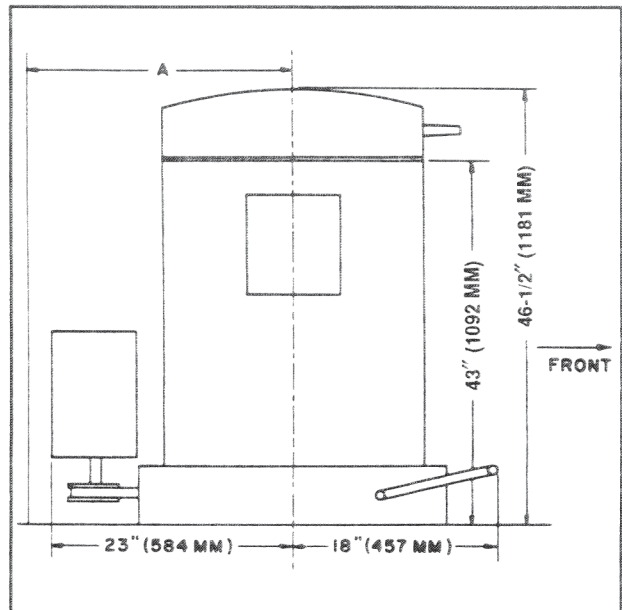

Figure 2-6

**NOTE:** The lid can swing to either side on all models. Also the control box can be installed on either side. For the dryers equipped with the Soft Start option, the control box will require switching from side to side. Moving the control box from the factory-installed position should only be done by a qualified electrician.

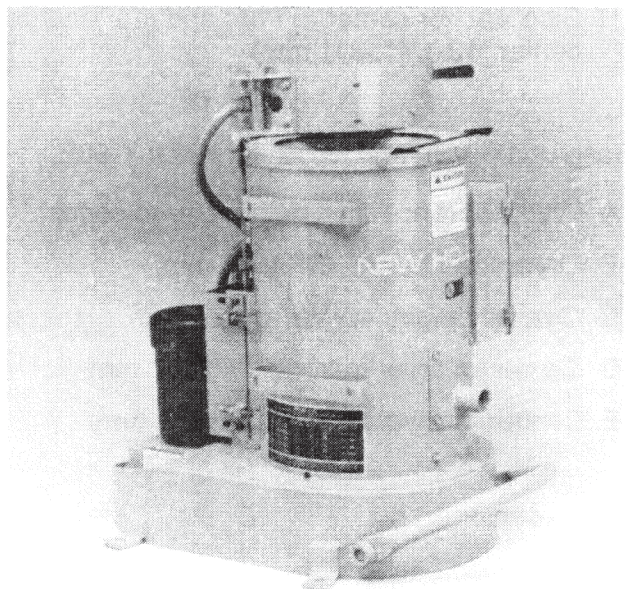

Figure 2-7

When planning your dryer location consider the location of the electrical power supply and requirement, the installation of an adequate drain, and is the dryer equipped with electric or steam heat.



**CAUTION: TO INSURE SAFE OPERATION, PLAN A DRAIN INSTALLATION, ADEQUATE IN SIZE AND PROPERLY LOCATED, WHICH WILL CARRY AWAY FLUIDS BEING REJECTED BY THE DRYER. SLIPPERY FLOORS, AS WELL AS INCREASED SHOCK HAZARD, RESULT IF OPERATORS MUST WADE OVER WET FLOORS.**

**WARNING: SAFE AND PROPER INSTALLATION OF ELECTRICAL EQUIPMENT IS CRITICAL TO THE SAFETY OF THE USER. UTILIZE EXPERIENCED AND**

**KNOWLEDGEABLE ELECTRICIANS TO CONNECT YOUR NEW HOLLAND DRYER TO THE POWER SYSTEM. INSIST ON PRACTICES AND MATERIALS AS SPECIFIED IN THE LATEST NATIONAL ELECTRICAL CODE AS WELL AS ANY APPLICABLE LOCAL CODES. USE OF UNDERWRITERS LABORATORIES APPROVED OR RECOGNIZED COMPONENTS IS HIGHLY RECOMMENDED.**

Intelligent planning of dryer location in regard to related shop components does little to improve actual dryer efficiency but does much to obtain good overall operating efficiency. A hoist is desirable to handle heavy basket loads. However, dryer location and orientation relative to the hoist travel path will both ease loading and unloading operations and greatly reduce the amount of fluid that can splash on the electrical control area when moving dripping baskets.

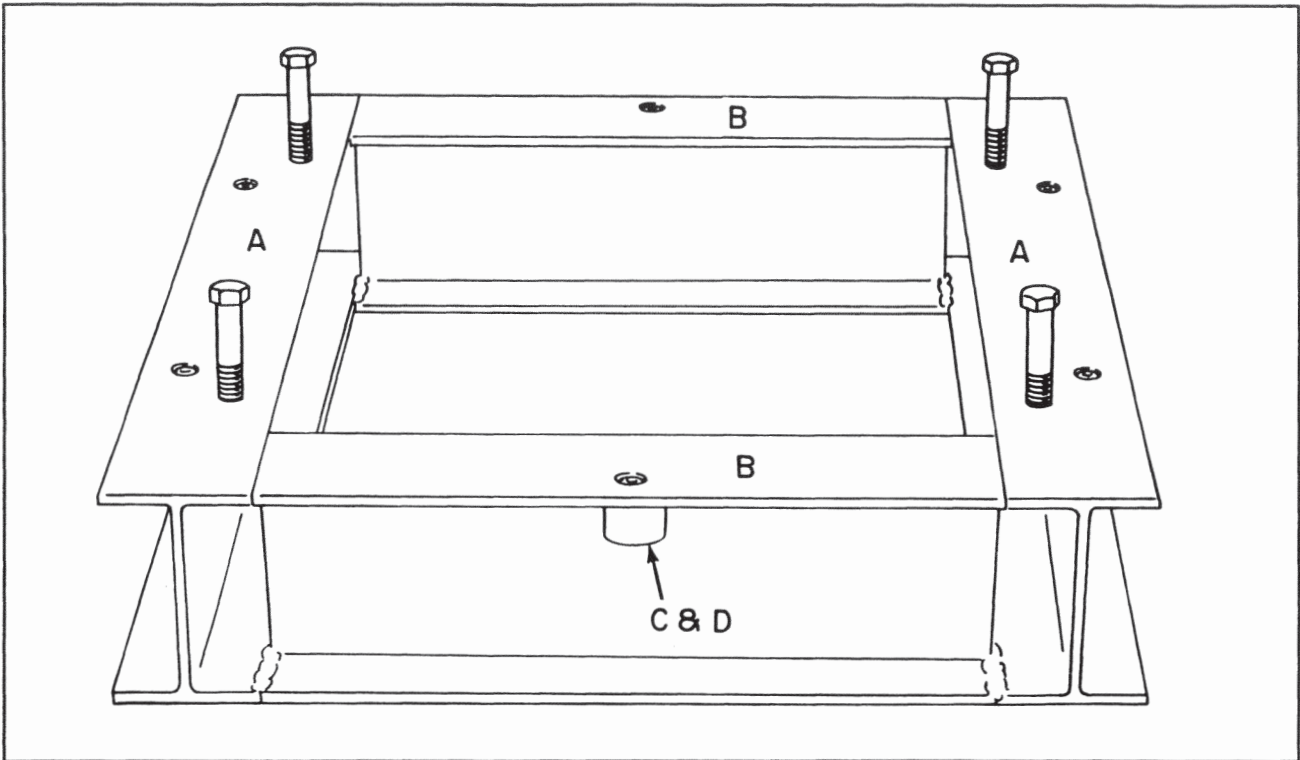

Figure 2-8

**FLOOR SUPPORT FRAME**

The dryers and chip-wringers must be installed securely to prevent vibration and damage to the dryer base.

During operation of the dryer with varying loads of material, volume and weight the dryer may vibrate.

If the dryers are not securely fastened, damage may occur to the dryer base and the floor mounting allowing the dryer to become loose.

To ensure the dryers have a good solid base the following floor mounting frame is recommended.

The welded steel floor mounting frame shown is made with 6" I Beam.

Material required:

- A (2) I Beams cut to 30" in length.
- B (2) I Beams cut to 19" in length.
- C (4) 2" x 2" Threaded blocks (K-24)
- D (6) 2" x 2" Threaded blocks (K-90, K-90E, K-94)



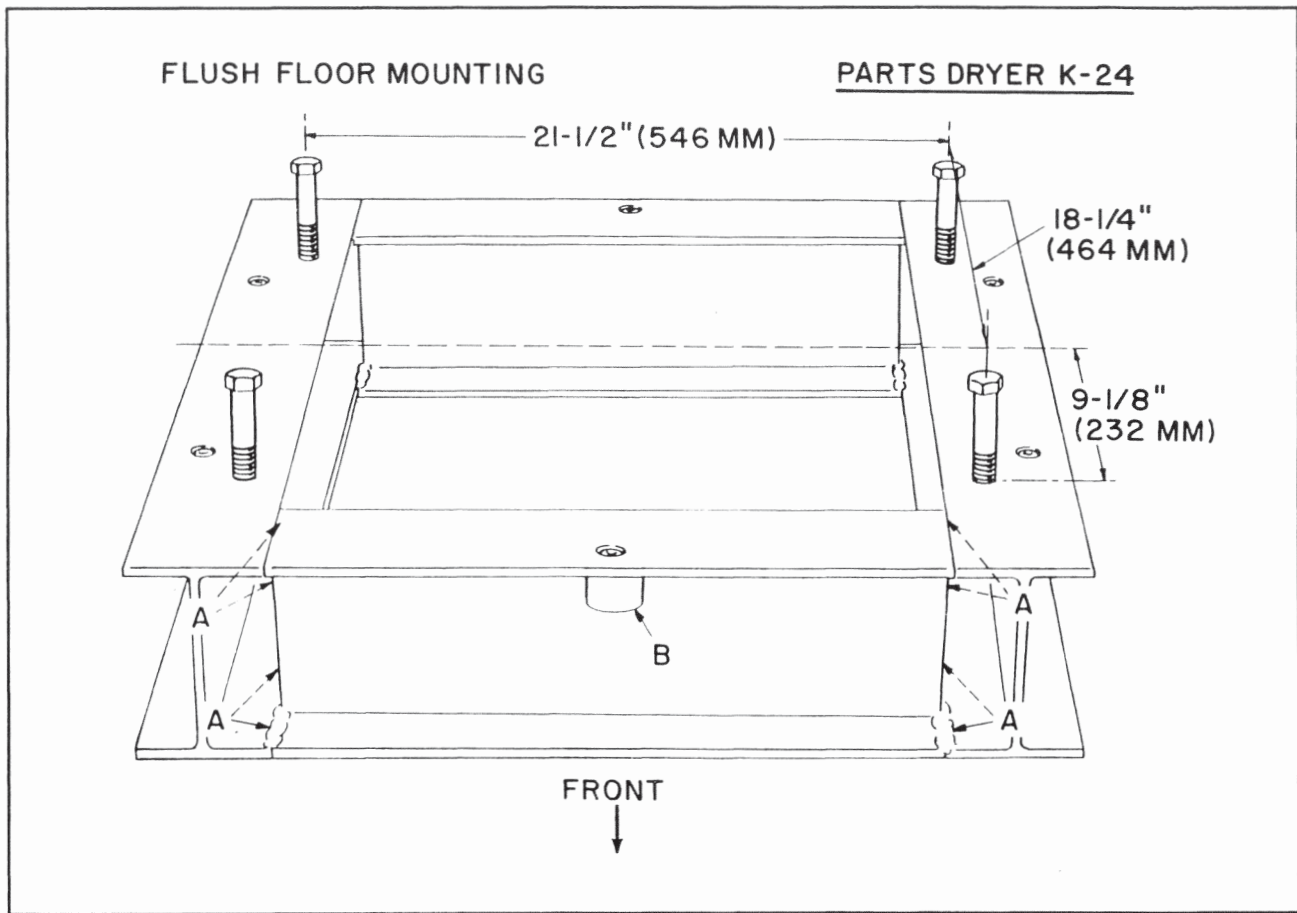

Figure 2-9

**Floor Frame Assembly: K-24**

K-24 requires four mounting holes.

Set the I beams square and with the top surface flat. Weld the four I-beams at A, on all corners keeping the top surface flat. Make sure the welds are getting proper penetration into the I-beams to ensure a solid frame.

Mark the top rails of the I beam frame and drill holes where marked for the model dryer being installed.

Place the 2" x 2" blocks centered under the top rail holes and mark the blocks B. Drill the blocks and tap the block for 5/8" x 2" grade 5 bolts.

Weld the threaded blocks under the top rails.

Now the dryer mounting frame is ready for installation into the floor.

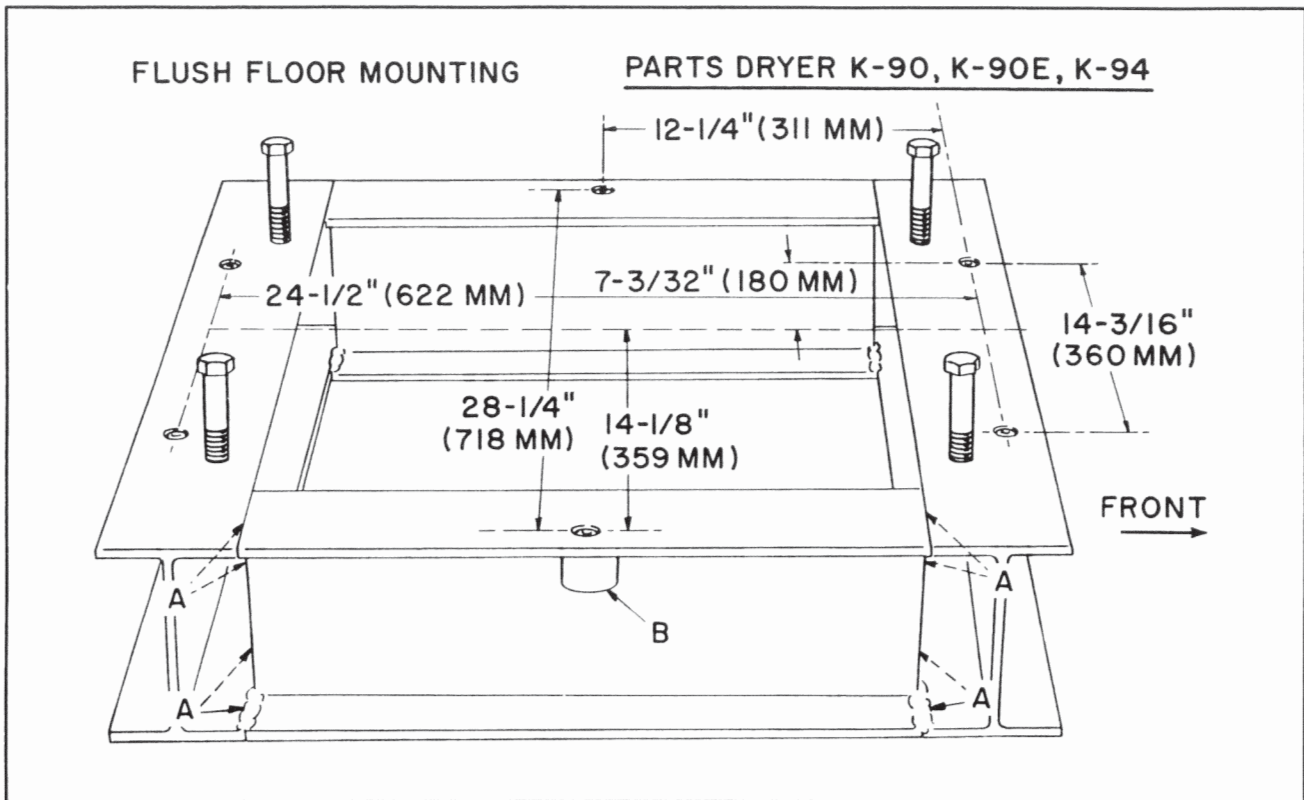

Figure 2-10

**Floor Frame Assembly: K-90, K-90E, K-94**

K-90, K-90E, K-94 requires six mounting holes.

Set the I beams square and with the top surface flat. Weld the four I-beams at A, on all corners keeping the top surface flat. Make sure the welds are getting proper penetration into the I-beams to ensure a solid frame.

Mark the top rails of the I beam frame and drill holes where marked for the model dryer being installed.

Place the 2" x 2" blocks centered under the top rail holes and mark the blocks B. Drill the blocks and tap the block for 5/8" x 2" grade 5 bolts.

Weld the threaded blocks under the top rails.

Now the dryer mounting frame is ready for installation into the floor.

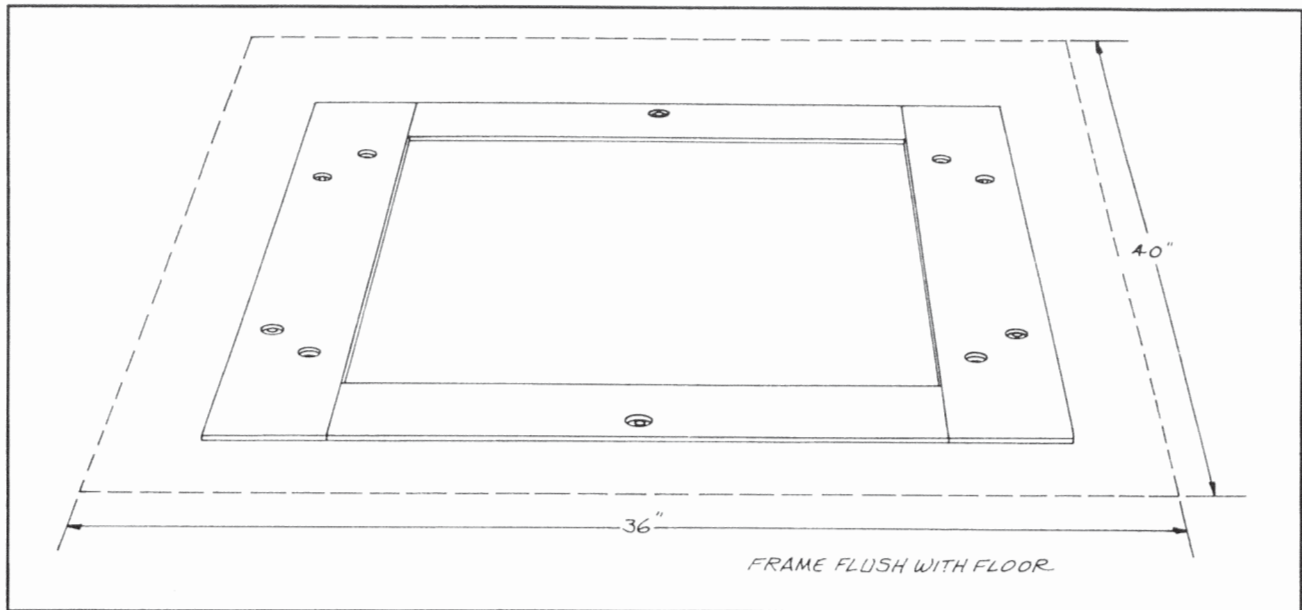

Figure 2-11

### FLOOR PREPARATION

Cut and excavate a hole in the existing floor 36" x 40" x 10" deep.

**NOTE:** The front of the K-24 Dryer can be positioned to the 36" width as shown in drawing.

**NOTE:** The K-90, K-90E, K-94 Dryers can be positioned to the 40" length side or can be rotated to an angle of any one support.

Bolt pipes or angle iron across the frame and insert the welded frame base into the hole. The support bolted to the frame will support the frame and keep the top surface level with the floor surface. This will allow the dryer to set on the steel frame to provide a solid surface.

Grease and install hardware in the remaining threaded blocks to prevent concrete from entering the blocks.

Fill the hole with concrete, working the concrete around the I Beam frame to ensure a solid base for the dryer.

**NOTE:** Before dryer installation and operation, be sure the fresh concrete is fully cured for maximum strength to prevent loosening of the base frame. Most concrete curing cycles are 28 days for maximum strength.



**CAUTION:** TO INSURE SAFE OPERATION, PLAN A DRAIN INSTALLATION, ADEQUATE IN SIZE AND PROPERLY LOCATED, WHICH WILL CARRY AWAY FLUIDS BEING REJECTED BY THE DRYER. SLIPPERY FLOORS, AS WELL AS INCREASED SHOCK HAZARD, RESULT IF OPERATORS MUST WADE OVER WET FLOORS.

## DRYER INSTALLATION

Set the dryer on the support and install 5/8" grade 5 bolts, making sure the dryer is level and properly secured for safe and satisfactory operation.

Torque the bolts to 128 ft. lbs. (174 N·m) unplated or silver plated, 165 ft. lbs. (224 N·m) gold plated.



**CAUTION: BEFORE DRYER OPERATION, BE SURE THE FRESH CONCRETE IS FULLY CURED FOR MAXIMUM STRENGTH TO PREVENT LOOSENING OF THE BASE FRAME.**

## WIRING

1. Use copper supply conductors from the fused circuit disconnect switch to the terminal block. The terminal block is not approved for use with aluminum conductors.
2. Customer supplied components include:
  - Fused disconnect switch
  - Conduit
  - Supply conductors
  - Grounding conductors
  - Steam lines for steam dryers
  - Steam cut off valves for steam dryers

These components shall comply in type and method of installation with the requirements of the current National Electrical Code and any applicable local codes.

3. The overload relay heaters required are determined after the voltage is known and the motor is selected. Refer to the motor rating plate and heater chart to be sure the overload protection properly matches the load requirements.
4. The motor, and electric heat element must match the line voltage used. All components on the unit are matched for the voltage indicated on the serial tag.



**WARNING: SAFE AND PROPER INSTALLATION OF ELECTRICAL EQUIPMENT IS CRITICAL TO THE SAFETY OF THE USER. UTILIZE EXPERIENCED AND KNOWLEDGEABLE ELECTRICIANS TO CONNECT YOUR NEW HOLLAND DRYER TO THE POWER SYSTEM. INSIST ON PRACTICES AND MATERIALS AS SPECIFIED IN THE LATEST NATIONAL ELECTRICAL CODE AS WELL AS ANY APPLICABLE LOCAL CODES. USE OF UNDERWRITERS LABORATORIES APPROVED OR RECOGNIZED COMPONENTS IS HIGHLY RECOMMENDED.**

The following charts can be used in determining the electrical requirements for the various model dryers and dryer voltages.

## HEATERS (OPTIONAL)

Electric heat units have the heat element prewired. Units equipped with the steam condenser must be connected to steam lines which should be limited or relieved of pressures in excess of 75 PSI (517 kPa or 5.2 bar). Flexible hose lines to connect the steam lines to the condenser are provided with the dryer. Keep flexing of the hoses to a minimum to prolong hose life.



## MODEL K-24

NEW HOLLAND INDUSTRIAL DRYER - 3 PHASE - 60HZ (EXCEPT 380V-50HZ)  
ELECTRICAL DIAGRAM-855026

<u>VOLTAGE</u>	<u>TYPE UNIT*</u>	<u>FULL LOAD CURRENT (AMP)</u>	<u>MIN CIRCUIT AMPACITY</u>	<u>MAX RATING ON SUPPLY FUSE</u>	<u>HEAT ELEMENT WATTS RATED V</u>
208	PLAIN & STEAM	4.1	5.1	FRN 5 <sup>5/10</sup>	--
208	W/ELECT HEATER	18.5	23.1	FRN 25 +	3000 + 208V
220	PLAIN & STEAM	3.8	4.7	FRN 5	--
220	W/ELECT HEATER	19.1	23.9	FRN 25	4000 230V
380	PLAIN & STEAM	2.1	2.6	FRS 2 <sup>9/10</sup>	--
380	W/ELECT HEATER	12.6	15.8	FRS 17 <sup>1/2</sup>	4000 380V
440	PLAIN & STEAM	1.9	2.4	FRS 2 <sup>1/2</sup>	--
440	W/ELECT HEATER	9.5	11.9	FRS 12	4000 460V
550	PLAIN & STEAM	1.5	1.9	FRS 2	--
550	W/ELECT HEATER	8.2	10.3	FRS 12	4000 575V

\* PLAIN & STEAM-MAX RUNNING AMPERAGE ANTICIPATED FOR MOTOR. CHECK MOTOR PLATE-ACTUAL AMPERAGE MAY VARY. W/ELECT HEATER-VALUES FOR MOTOR PLUS STANDARD HEAT ELEMENT. + = 4000 W. ELEMENT OPT. FOR 208V UNIT; USE FRN 30 SUPPLY FUSES.

855047

## MODEL K-90

NEW HOLLAND INDUSTRIAL DRYER - 3 PHASE - 60HZ (EXCEPT 380V-50HZ)  
ELECTRICAL DIAGRAM-855026

<u>VOLTAGE</u>	<u>TYPE UNIT*</u>	<u>FULL LOAD CURRENT (AMP)</u>	<u>MIN CIRCUIT AMPACITY</u>	<u>MAX RATING ON SUPPLY FUSE</u>	<u>HEAT ELEMENT WATTS RATED V</u>
208	PLAIN & STEAM	7.8	9.8	FRN 10	--
208	W/ELECT HEATER	22.2	27.8	FRN 30 +	3000 + 208V
220	PLAIN & STEAM	7.1	8.9	FRN 10	--
220	W/ELECT HEATER	22.4	28.0	FRN 30	4000 230V
380	PLAIN & STEAM	3.7	4.6	FRS 5	--
380	W/ELECT HEATER	14.2	17.8	FRS 20	4000 380V
440	PLAIN & STEAM	3.6	4.5	FRS 4.5	--
440	W/ELECT HEATER	11.2	14.0	FRS 15	4000 460V
550	PLAIN & STEAM	2.8	3.5	FRS 3.5	--
550	W/ELECT HEATER	9.5	11.9	FRS 12	4000 575V

\* PLAIN & STEAM-MAX RUNNING AMPERAGE ANTICIPATED FOR MOTOR. CHECK MOTOR PLATE-ACTUAL AMPERAGE MAY VARY. W/ELECT HEATER-VALUES FOR MOTOR PLUS STANDARD HEAT ELEMENT. + = 4000 W. ELEMENT OPT. FOR 208V UNIT; USE FRN 35 SUPPLY FUSES.

855048

## MODEL K-90E

NEW HOLLAND INDUSTRIAL DRYER - 3 PHASE - 60HZ  
ELECTRICAL DIAGRAM-855026

VOLTAGE	TYPE UNIT*	FULL LOAD CURRENT (AMP)	MIN CIRCUIT AMPACITY	MAX RATING ON SUPPLY FUSE	HEAT ELEMENT WATTS RATED V
208	PLAIN	7.8	9.8	FRN 10	--
208	W/ELECT HEATER	22.2	27.8	FRN 30 +	3000 + 208V
220	PLAIN	7.1	8.9	FRN 10	--
220	W/ELECT HEATER	22.4	28.0	FRN 30	4000 230V
440	PLAIN	3.6	4.5	FRS 4.5	--
440	W/ELECT HEATER	11.2	14.0	FRS 15	4000 460V

\* PLAIN DRYER - MAX RUNNING AMPERAGE ANTICIPATED FOR MOTOR. CHECK MOTOR PLATE- ACTUAL AMPERAGE MAY VARY. W/ELECT HEATER-VALUES FOR MOTOR PLUS STANDARD HEAT ELEMENT. + = 4000 W. ELEMENT OPT. FOR 208V UNIT; USE FRN 35 SUPPLY FUSES.

855049

## MODEL K-94

NEW HOLLAND INDUSTRIAL DRYER - 3 PHASE-60HZ (EXCEPT 380V-50HZ)  
ELECTRICAL DIAGRAM-855026

VOLTAGE	TYPE UNIT	FULL LOAD CURRENT (AMP)	MIN. CIRCUIT AMPACITY	MAX RATING ON SUPPLY FUSE	HEAT ELEMENT WATTS RATED V
208	PLAIN & STEAM	11.7	14.6	FRN 15	-----
208	W/ELECT HEATER	26.1	32.6	FRN 35	3000 208V
208	W/OPT. EL. HT. ELEMENT	30.9	38.6	FRN 40	(OPT) 4000 208V
220	PLAIN & STEAM	10.7	13.4	FRN 15	-----
220	W/ELECT HEATER	26.0	32.5	FRN 35	4000 230V
380	PLAIN & STEAM	5.6	7.0	FRS 8	-----
380	W/ELECT HEATER	16.1	20.1	FRS 25	4000 380V
440	PLAIN & STEAM	5.4	6.8	FRS 7	-----
440	W/ELECT HEATER	13.0	16.3	FRS 17 1/2	4000 460V
550	PLAIN & STEAM	4.2	5.3	FRS 5 6/10	-----
550	W/ELECT HEATER	10.9	13.6	FRS 15	4000 575V

PLAIN AND STEAM-MAX RUNNING AMPERAGE ANTICIPATED FOR MOTOR. CHECK MOTOR PLATE -ACTUAL AMPERAGE MAY VARY W/ELECT HEATER- VALUES FOR MOTOR PLUS STANDARD HEAT ELEMENT.

9802899

# SECTION 3

## OPERATION

### CONTROLS

All operating controls are placed for easy access on the face of the dryer control box.

The dryer control box can be moved to the left side of the dryer if necessary. On dryers equipped with the Soft Start Option the control boxes can be switched. Moving the control box should only be done by a qualified electrician.

A - Forward Button - Turns power on to dryer motor for forward direction.

B - Stop Button - Disconnects power to dryer motor.

C - Reverse Button - Turns power on to dryer motor for reverse direction.

*ATTENTION: Do not switch from forward to reverse or vice versa without first bringing the spinner to a full stop.*

D - Foot Brake - The foot brake is used to stop spinner rotation before opening the dryer cover. Depressing the brake will disconnect power to the dryer motor by mechanically tripping switch, F, Figure 3-2, turning "OFF" power to the motor and heater element if equipped with electric heat. Pushing the brake control farther will release cover latch, G, Figure 3-2, and allow the cover to be moved to either the left or right for spinner basket removal.

E - Spinner Cover - After fully depressing the brake control, the cover can be swung to the left or right. If the dryer is equipped with optional electrical or steam heat, the heater element is enclosed in the cover assembly.

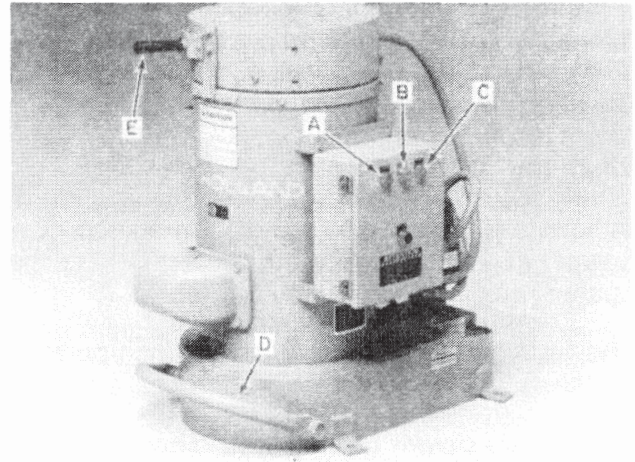

Figure 3-1



**CAUTION: IF THE DRYER IS EQUIPPED WITH ELECTRIC OR STEAM HEAT DO NOT TOUCH THE LID OR SERIOUS INJURY COULD OCCUR.**



## OPTIONAL ELECTRIC LID HEATER

Electric Heat Switch with Indicator Light - Dryers equipped with electric heat have switch, A, to turn power on to the heater only. Power will remain on to the heater while the spinner is in operation. The power to the heater will automatically be cut off when the stop button B, or the brake C, is depressed to stop the spinner.

When the FORWARD, D, or REVERSE, E, buttons are pressed to restart the spinner, the power will automatically be turned "ON" to the heater.

The switch has an indicator light incorporated and shows when power is on to the heat element.

**NOTE: The power to the electric heat element is only on during spinner operation and will be "OFF" when spinner is not in operation even if the heat button was pressed.**

If no heat is required press the heater button, A, to turn off the power to the heater.



**CAUTION: DO NOT USE ELECTRIC HEAT WHEN WORKING WITH FLAMMABLE MATERIAL.**

## SOFT-START MOTOR CONTROLLER (Optional)

The soft-start motor controller, A, can be adjusted for different applications and dryer loads.

The softness of the start is controlled by the setting of the start time and initial starting torque.

When properly set, the motor will start rotating when the start button is pressed, and the dryer will start spinning with a smooth uninterrupted start.

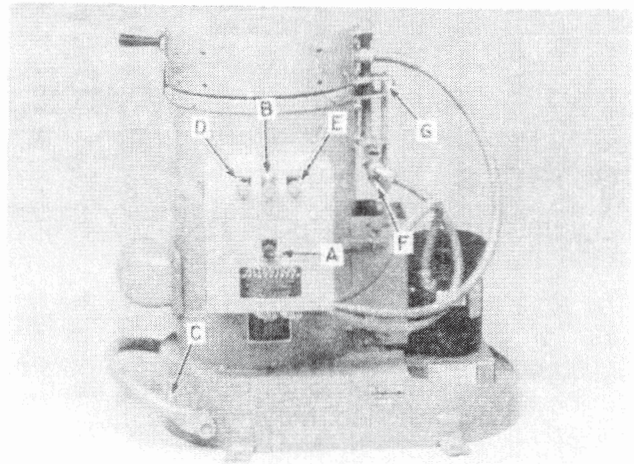

Figure 3-2

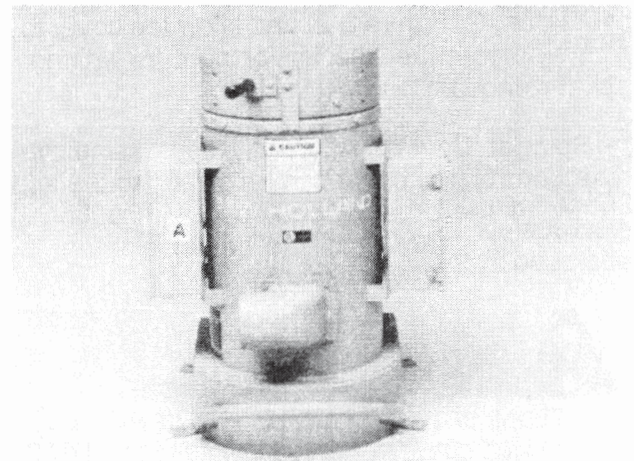

Figure 3-3



## OPERATING THE DRYER



**WARNING:** NEW HOLLAND DRYERS CONTAIN A SAFETY CONTROL CIRCUIT WHICH PREVENTS DRYER OPERATION WITH THE LID OPEN AND AUTOMATIC RESTART FOLLOWING ANY POWER OUTAGE. THIS CIRCUIT WAS DESIGNED WITH THE SAFETY OF THE USER IN MIND. UNDER NO CIRCUMSTANCES SHOULD ANY MECHANICAL OR ELECTRICAL DEVICE BE ADDED, ELIMINATED, OR MODIFIED TO CIRCUMVENT OR DEFEAT THE PURPOSE OF THIS SAFETY CIRCUIT.

When a basket of parts (or load of egg flats) is ready for drying, follow this procedure:

1. Depress the brake pedal to unlatch the lid. Swing the lid open.
2. Lower the basket (or flats) into the dryer. Rotate the basket slightly by hand with your foot on the brake to insure proper driving lug engagement with the bars on the basket. See A, Figure 3-4 (without basket), and Figure 3-5 (with basket). This ensures that bars, B, on the bottom of the basket, Figure 3-5, are not on top of lugs, A. If bars, B, are on top of lugs, A, on start-up, the dryer will knock for several seconds until the basket settles between lugs, A. This slipping (knocking) will cause the lugs and bars to wear as they slip over the lugs.

*IMPORTANT: Check the parts in the basket for relatively even distribution which will result in a relatively balanced basket and less machine vibration.*



**CAUTION:** AVOID MOVING DRIPPING PARTS OR BASKETS OVER THE ELECTRIC CONTROL BOX AND MOTOR.

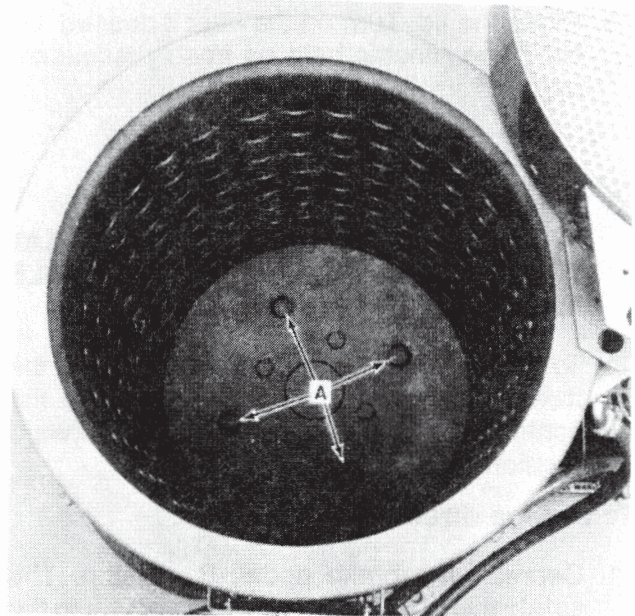

Figure 3-4

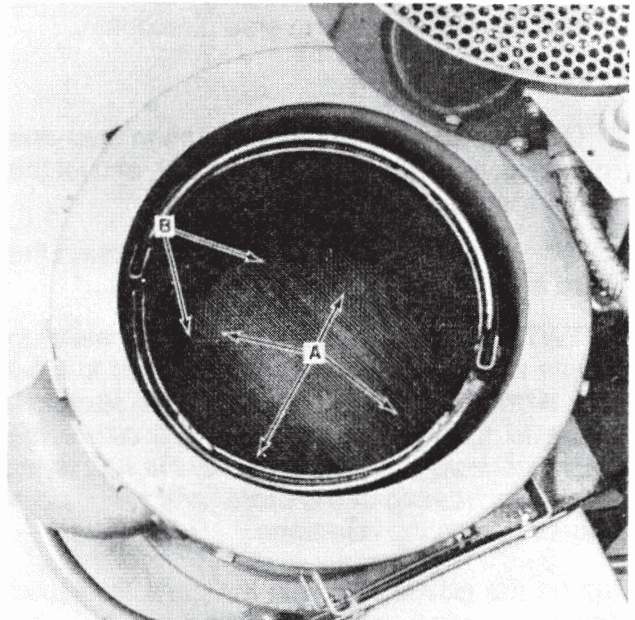

Figure 3-5

3. Close the lid. Turn on the heat if desired. Do NOT use electric heat on freshly lacquered parts.



**CAUTION: DO NOT USE ELECTRIC HEAT WHEN WORKING WITH FLAMMABLE MATERIAL.**

4. To start rotation of the dryer, depress the forward button, A, which will energize the control circuit. The unit will begin forward rotation.

**To change direction of the dryer:**

1. Depress the brake pedal, B, to stop. The safety switch will disconnect the power to the control circuit, turning off the motor. Continue holding the brake until sounds of rotation cease and then release the brake pedal.
2. Depress the reverse button, C, to start the unit spinning in the reverse direction.

**To stop the unit:**

1. Depress the brake pedal, B, as in step one above, or depress stop button, D, and let the spinner coast to stop.
2. With your foot on the brake pedal, open the lid after all sound of rotation ceases.

**ATTENTION:** Do not switch from forward to reverse without first bringing the basket to a full stop. With the brake, this takes only seconds. Failure to follow this instruction will cause the motor overload protection to shut the unit down due to overheating of the motor and results in a delay of the drying operation.

Turn on the power and spin the parts for a brief interval. If drying shaped or light parts, stop the dryer and spin the parts in the opposite direction for a period of time.

Experience will teach you how long the drying operation should continue to attain well-dried parts.

If drying small or light parts and the load becomes out of balance, and the dryer starts to vibrate, stop spinner rotation and reverse direction to allow the parts to become stable in the basket.

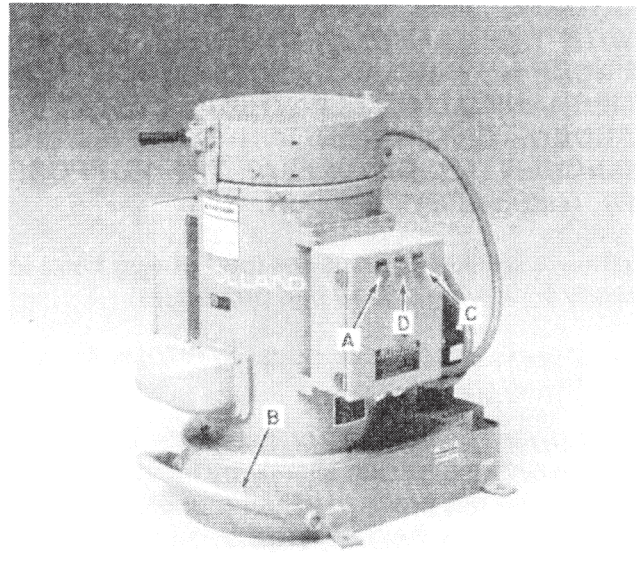

Figure 3-6



## OPERATION

---

When the parts are believed to be dry, stop the motor and depress the brake, bringing the rotating carrier to a halt. With the brake pedal still depressed, open the lid. Examine the parts. Remove the parts, if dry, or close the lid and respin if added drying time is required.

### **To stop the unit:**

1. Depress the stop button, then the brake pedal to bring the rotating spinner to a stop.
2. With your foot on the brake pedal, open the lid after all sound of rotation ceases.

If the unit stops without depressing the stop button or brake pedal:

1. Determine if power is still available to the unit. If there is no power, check for a blown disconnect fuse and correct the cause. If there is a general power outage, await resumption then follow the previous directions.
2. If power is available to the unit, the protective circuit has cut out, probably from motor overload. The usual cause of overload is changing motor rotation without proper use of the brake. Determine the cause and correct. Wait 30-45 seconds to restart, as the overload relay is an automatic reset type requiring at least 30 seconds to cool off.

## CHIP-WRINGER OPERATION

The models K-24 (shown), K-90, and K-94 industrial dryers can be built in a chip-wringer configuration and can be used to reclaim cutting oils from metal chips or shavings produced by screw machines, boring mills, grinders and other machining operations.

The operation of the Chip-wringer units is the same as for the standard dryers.

The New Holland Chip-wringers use centrifugal force to spin cutting oil from a basket of chips or shavings. Simultaneously, a turbine fan mounted below the basket pulls a powerful stream of air down through the parts load, then blows the coolant off the chips and toward the dryer drain.

In seconds, you get reusable oil and dry, salable chips.

After operating the chip-wringer for a few loads in your application, you will be able to determine the time required to separate the liquid from the chip or shavings.

Check the drain from the dryer periodically to allow the fluid to drain freely. If the drain becomes plugged it will slow down the time required to separate the fluid from the chips or shavings.



**CAUTION: TO INSURE SAFE OPERATION, USE A DRAIN, ADEQUATE IN SIZE AND PROPERLY LOCATED, WHICH WILL CARRY AWAY FLUIDS BEING REJECTED BY THE CHIP-WRINGER. SLIPPERY FLOORS, AS WELL AS INCREASED SHOCK HAZARD, RESULT IF OPERATORS MUST WADE OVER WET FLOORS.**

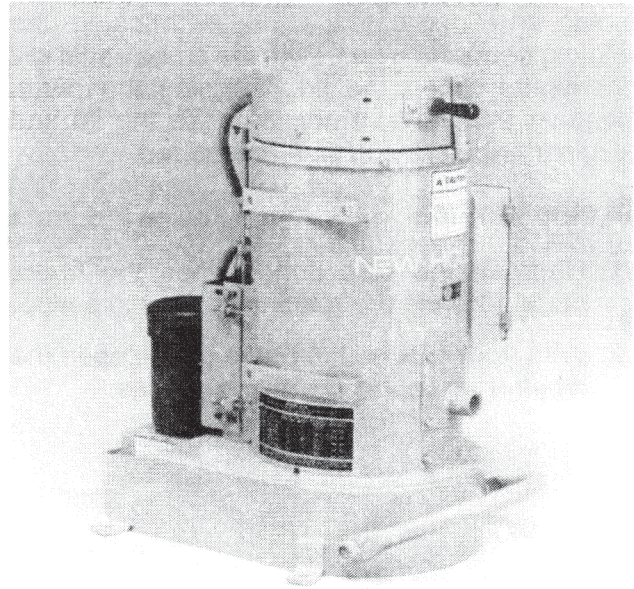

Figure 3-7

### K-90E EGG FLAT DRYER OPERATION

The K-90E egg flat dryer is a modified K-90 industrial dryer designed to quickly and efficiently dry up to 100 plastic egg flats per load.

Loading egg flats into the dryer.

1. Lower a stack of egg flats into the dryer with the drain holes in the egg flats down.

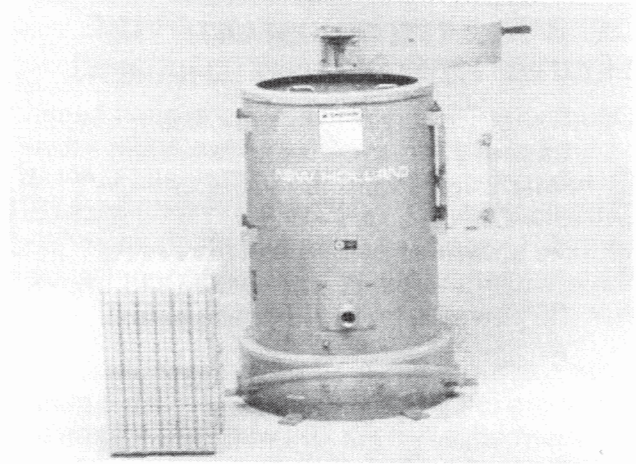

Figure 3-8

2. Add flats taking care that the top of the uppermost flat is no higher than the horizontal bends of the rod-type retainer weld assemblies, A.



**CAUTION: DO NOT SWING DRIPPING FLATS OVER THE ELECTRICAL CONTROL BOX OR MOTOR.**

The K-90E egg flat dryer can be equipped with electric heat. The operation of the dryer with an electric heating unit is basically the same as the standard dryer. Refer to the section OPERATING THE DRYER WITH ELECTRIC HEAT.

Check the drain from the dryer periodically to allow the water to drain freely. If the drain becomes plugged it will slow down the drying time.

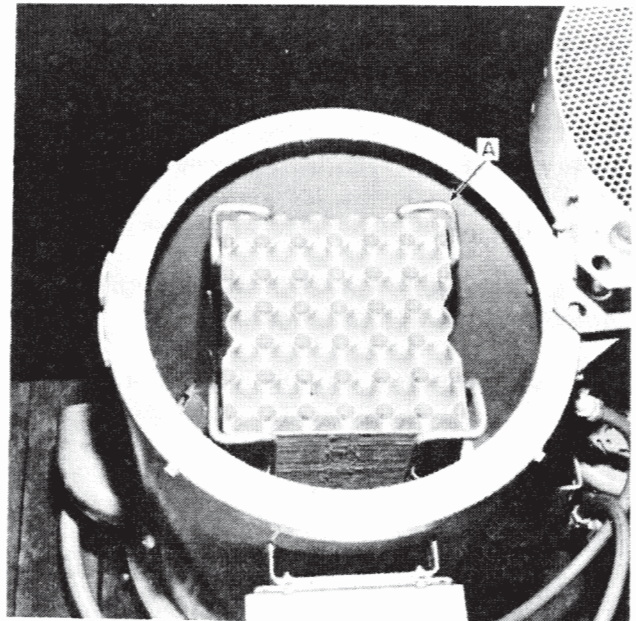

Figure 3-9



**CAUTION: TO INSURE SAFE OPERATION, USE A DRAIN, ADEQUATE IN SIZE AND PROPERLY LOCATED, WHICH WILL CARRY AWAY FLUIDS BEING REJECTED BY THE DRYER. SLIPPERY FLOORS, AS WELL AS INCREASED SHOCK HAZARD, RESULT IF OPERATORS MUST WADE OVER WET FLOORS.**



### OPERATING THE DRYER WITH THE ELECTRIC HEATING UNIT (Optional)

Operation of the dryer with the electric heating unit is basically the same as the standard dryer. The heater is wired at the factory and CAN BE TURNED ON OR OFF WITH THE HEATER SWITCH shown at A. The electric heater "ON" light is incorporated in the switch and shows when the power is on to the heat element.

Power will remain on to the heater while the spinner is in operation. The power to the heater will automatically be cut off when the stop button B, or the brake pedal, C, is depressed to stop the spinner. The heater will remain off until the forward, D, or reverse, E, buttons are pressed to start the spinner.

The switch has an indicator light incorporated and shows when power is on to the heat element.

**NOTE: The power to the electric heat element is only on during spinner operation and will be "OFF" when spinner is not in operation even if the heat button was pressed.**

If no heat is required press the heater button A, to turn off the power to the heater.

To conserve energy, turn off the electrical power to the lid heater when heat is not required.



**WARNING: DO NOT USE THE ELECTRICALLY HEATED DRYER ON LACQUERED PARTS, OR FLAMMABLE MATERIAL!**

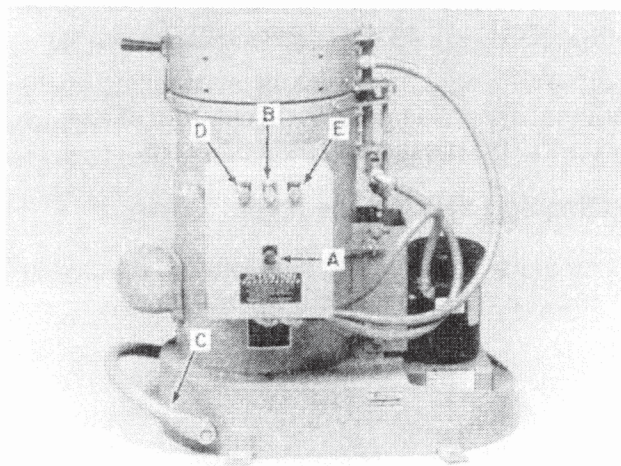

Figure 3-10

### OPERATING THE DRYER WITH THE STEAM HEATING UNIT (Optional)

The fin coiled steam element mounted in the cover lid is designed for either low or high pressure systems. The flexible hoses should be attached to the steam and return lines so that flexing of the hoses is kept to a minimum to prolong hose life.

The following chart shows the temperature rise you can expect in your steam-heated dryer for various steam pressures:

STEAM PRESSURE	APPROXIMATE TEMPERATURE RISE
12 PSI (0.83 bar)	90°F (32°C)
25 PSI (1.72 bar)	110°F (43°C)
50 PSI (3.45 bar)	120°F (49°C)
75 PSI (5.17 bar)	130°F (54°C)

**IMPORTANT:** Be sure to throw the disconnect switch "OFF" at the end of the shift or operating period.

### DRYER CAPACITY

The Model K-24 dryer is designed to handle 50 lbs. to 75 lbs. (23 kg-34 kg).

The Model K-90 dryer is designed to handle 100 lbs. to 150 lbs. (45 kg-68 kg).

The Model K-90E dryer is designed to handle 100 plastic egg flats at a time.

The Model K-94 dryer is designed to handle 200 lbs. to 250 lbs. (91 kg-113 kg).

Volume, not weight, is often the limitation of capacity, depending on the parts being dried. Do not fill the baskets to the point where the parts will centrifugally "climb the basket wall" during spinning and be thrown out of the basket.

#### ATTENTION:

1. Do not overload! Overloading is not economical and only abuses the equipment. For best results, distribute the weight uniformly in the basket.
2. Do not modify the spinner basket as received from New Holland as the basket is balanced to reduce machine vibration. Adding a lid or other devices will result in an unbalanced spinner that can cause machine vibration and eventual machine damage.





---

# SECTION 4

## LUBRICATION

### DRYER MOTOR

The motor is equipped with prepacked ball bearings. Lubricate the motor according to the manufacturer's specifications.

### MAIN BEARINGS

The spindle of the New Holland dryer rides on two large tapered roller bearings. A grease fitting is located on the front below the exhaust outlet for the main bearings, A. Two grease fittings, B, are provided to lubricate the brake pedal. Use a soft bearing grease with a high melting point. Only a small amount of grease should be added, the frequency depending on how much or how often the machine is used, usually every 30 days or 300 hours.

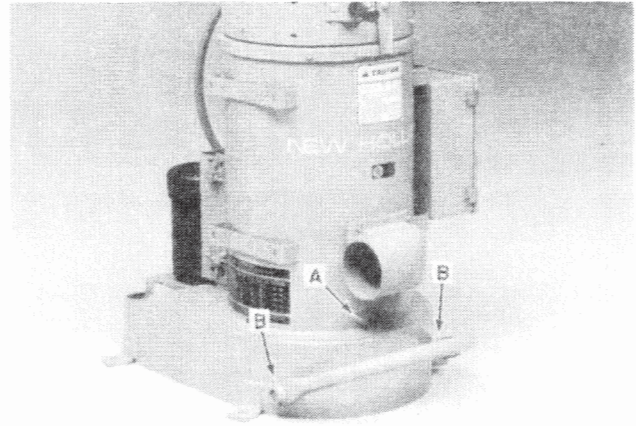

Figure 4-1

Bearing greases suitable for this lubrication requirement are as follows:

Texaco Marfak Multipurpose #2

Gulfcrown #2 (Gulflex A)

Shell Alvania EP2

Shell Super Duty

Exxon Ronex MP

\*Exxon Nebula EP #1

Lubriplate 1200-2

\*Factory-installed grease

**NOTE: The grease used should be a high-viscosity lithium base grease required for high temperatures.**



---

## SECTION 5

# ADJUSTMENTS AND MAINTENANCE



**WARNING: DO NOT ATTEMPT TO MAKE ADJUSTMENTS OR REPAIRS WITHOUT FIRST MAKING SURE THE MAIN ELECTRICAL SWITCH IS OFF AND LOCKED. IF THE DRYER IS EQUIPPED WITH A HEATER (STEAM OR ELECTRIC) MAKE SURE THE HEAT SOURCE HAS BEEN SHUT OFF OR DISCONNECTED WHERE NECESSARY SO THE DRYER CAN BE TIPPED ON ITS SIDE.**

**HAVE A QUALIFIED ELECTRICIAN DETERMINE AND CORRECT ANY SUSPECTED ELECTRICAL MALFUNCTION. IF ANY COMPONENT REPLACEMENT IS**

**REQUIRED, ORDER THE REPLACEMENT FROM NEW HOLLAND TO INSURE PROCUREMENT OF RELIABLE COMPONENTS HAVING UNDERWRITERS LABORATORIES APPROVAL OR RECOGNITION.**

**THE DRIVE COMPONENTS WILL CONTINUE TO ROTATE AFTER THE POWER IS TURNED OFF. USE THE BRAKE TO STOP FREE SPINNING OF THE ROTATING COMPONENTS AND BASKET. LOOK AND LISTEN TO DETERMINE THAT ALL MOTION HAS STOPPED BEFORE REMOVING THE PROTECTIVE SHIELDS. REPLACE ALL SHIELDS BEFORE RESTARTING.**

## ADJUSTING AND REPLACING BELTS

Periodic belt inspection is necessary for adequate belt life. A squeal on start-up is a sure sign of loose belts.

### K-24 BELT ADJUSTMENT

1. To tighten the belts, loosen the four bolts at A (two on each side of the dryer).
2. Loosen nuts, B, on lower setscrews, C, and adjust setscrews, C, and nuts, D, on the top drawbolts until the belts are tight enough to handle normal operating loads in the dryer. Normal belt tension is 1/4" (6.35 mm) deflection at the center of the span with 3 1/2 lbs. (1.59 kg) force.
3. Retighten the four bolts at A.
4. After tightening the belts, reposition shield, E, if the motor shaft or belt sheave contacts the shield. Move the shield by loosening bolts, F, on both sides of the dryer.

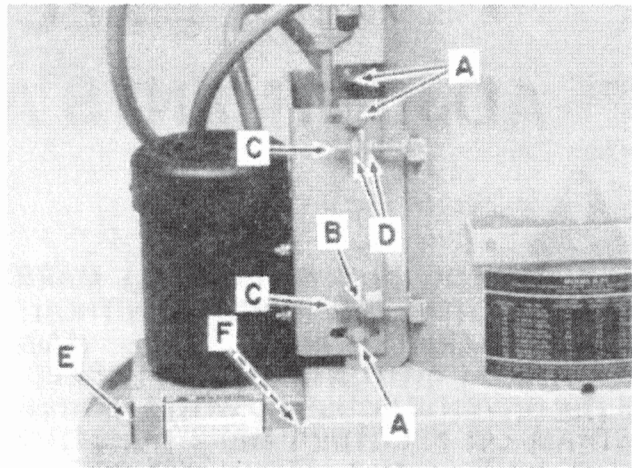

Figure 5-1

### K-24 BELT REPLACEMENT

If new belts are needed, be sure to install a matched set.



**CAUTION: DISCONNECT THE POWER AND HEAT SOURCE TO THE DRYER BEFORE ATTEMPTING BELT REPLACEMENT.**

1. Remove shield, A, by removing two nuts, B, one on each side of the shield. Loosen the motor mount and adjusting hardware.

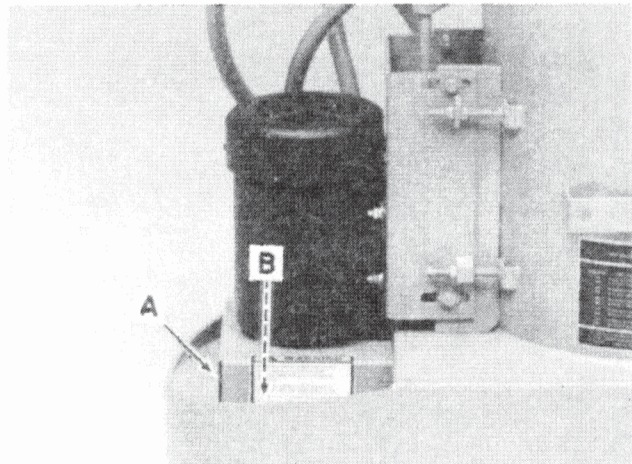

Figure 5-2



2. Remove the hardware used to secure the dryer to the floor. Using an adequate hoist, tip the dryer on its side as shown.
3. Remove bolt, A, joining the rear of the brake linkage to the rear lid latching rod. The linkage bars can be easily removed from the pivot pin at B.
4. Install the new matched belt set, being sure the belts are not twisted.
5. Return the brake to the operating position by installing the linkage on pivot pin, B, and securing with bolt, A. Tighten the bolt securely.
6. Using a hoist, return the dryer to the upright position. Secure the dryer to the floor, making sure the base is level and the securing hardware is tight.
7. Retension the belts as previously described in "BELT ADJUSTMENT."
8. Reinstall shield, A, using two nuts, B, previously removed, Figure 5-2.
9. Turn on the power to the dryer and check for proper operation.

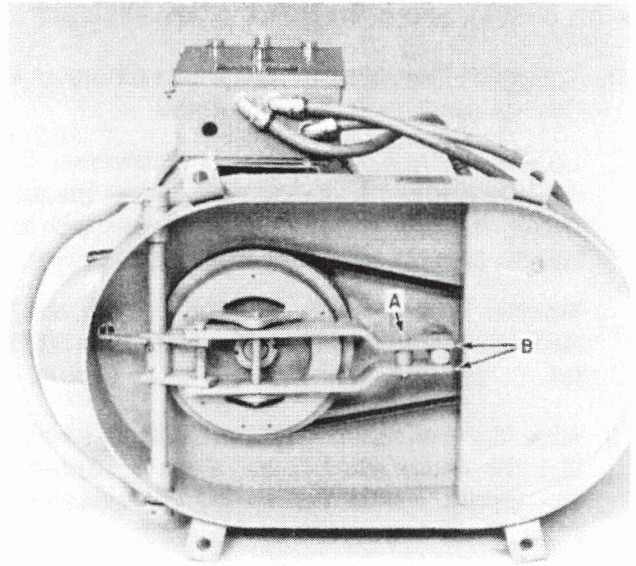

Figure 5-3

### K-90, K-90E, and K-94 BELT ADJUSTMENT

1. To tighten the belts, loosen the four bolts at A (two on each side of the dryer).
2. Loosen nuts, B, on the lower setscrews, C. Adjust setscrews, C, and nuts, D, on the top drawbolts until the belts are tight enough to handle normal operating loads in the dryer.

Normal belt tension is 5/16" (7.93 mm) deflection at the center of the span with 3 1/2 lbs. (1.59 kg) force.

3. After tightening the belts, reposition shield, E, if the motor shaft or belt sheave contacts the shield. Move the shield by loosening bolts, F, on both sides of the dryer.

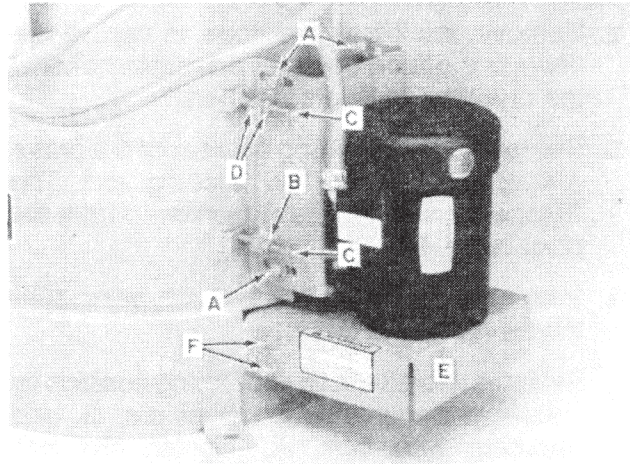

Figure 5-4

### K-90, K-90E, and K-94 BELT REPLACEMENT

If new belts are needed, be sure to install a matched set.



**CAUTION: DISCONNECT THE POWER AND HEAT SOURCE TO THE DRYER BEFORE ATTEMPTING BELT REPLACEMENT.**

1. Remove shield, A, by removing nuts, B, two on each side of the shield. Loosen the motor mount and adjusting hardware.
2. Remove the hardware used to secure the dryer to the floor. Using an adequate hoist, tip the dryer on its side as shown.

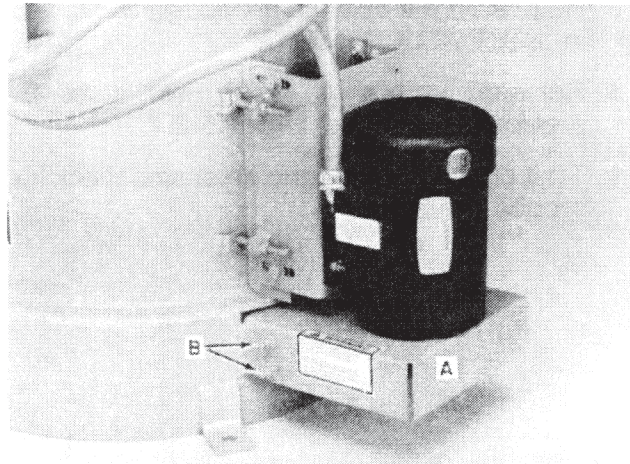

Figure 5-5



3. Remove bolt, A, joining the rear of the brake linkage to the rear lid latching rod. Remove pins, B and C, then linkage bars can be easily removed from the pivot pin at D.
4. Install the new matched belt set, being sure the belts are not twisted.
5. Return the brake to the operating position by installing the linkage on pivot pin, B, securing with bolt, A, and installing pins, B and C. Tighten the bolt securely.
6. Using a hoist, return the dryer to the upright position. Secure the dryer to the floor, making sure the base is level and the securing hardware is tight.
7. Retension the belts as previously described in "Belt Adjustment."
8. Reinstall shield, A, using hardware, B, Figure 5-5.
9. Turn on the power to the dryer and check for proper operation.

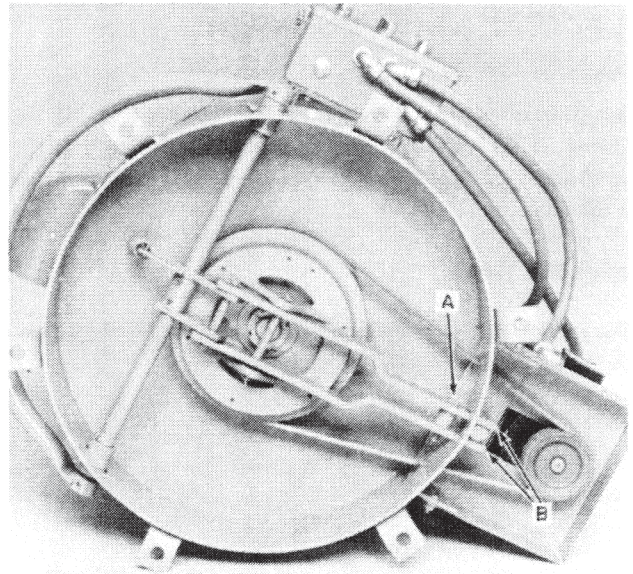

Figure 5-6

### LID ADJUSTMENT

The dryer lid can be adjusted so the lid is centered on the dryer by loosening bolts, A.

Maintain an 1/8" (3.2 mm) minimum clearance between the lid and dryer. This can be obtained by adjusting set collars, B, on the pivot shaft.

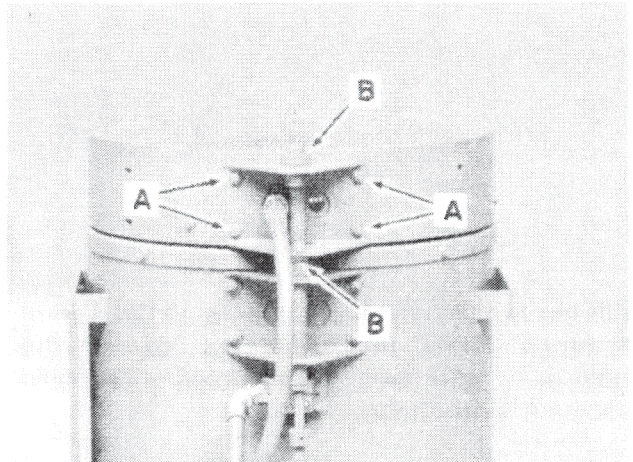

Figure 5-7



## ELECTRIC SAFETY SWITCH ADJUSTMENT

The safety switch must be on when the lid is closed and off as the brake pedal is being depressed. Check the following areas and adjust as required:

### Latching Rod

The cover should remain latched until the brake pedal is almost fully depressed, A.

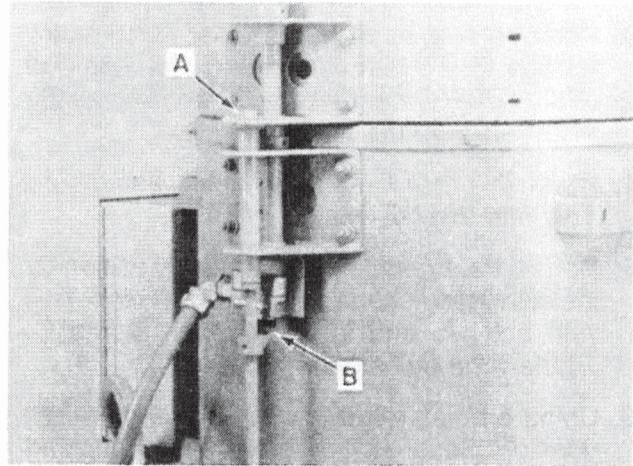

Figure 5-8

If vertical adjustment is required, thread the upper portion of the rod into or out of the clevis nut as required, A. The rod should just clear the cover with the brake fully applied.

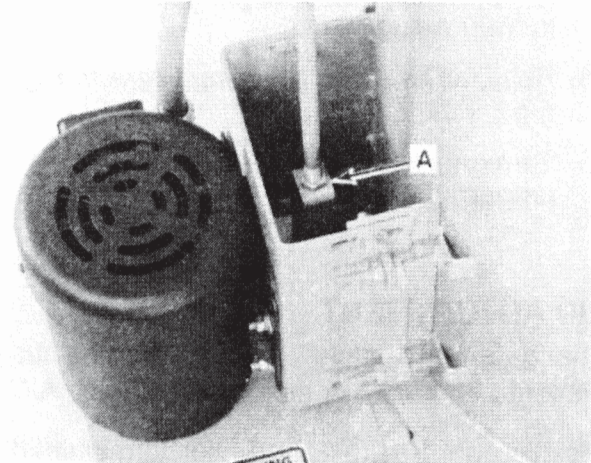

Figure 5-9

With the brake fully depressed, a 1" (25.4 mm) clearance should be maintained between the brake lever and floor, A. Less clearance could indicate a worn brake.

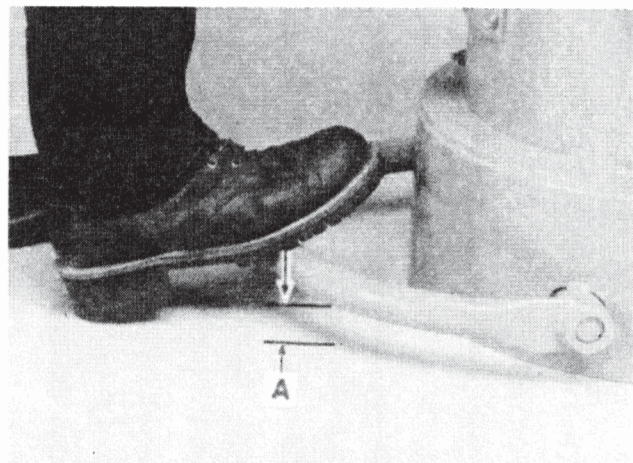

Figure 5-10



### Switch Adjustment

The cast limit stop is adjusted by using a setscrew. Limit stop, A, should just fully depress switch button, B, with the latching rod in its fully up position. When the brake is depressed, the rod moves downward and should move clear of the limit switch button, B, by the time the cover is free to swing, A, Figure 5-5.

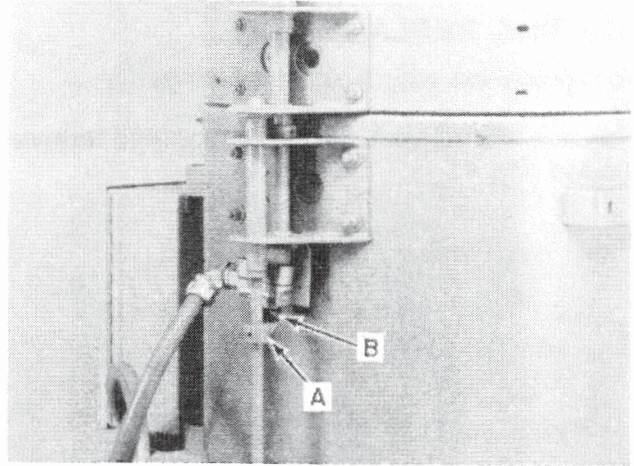

Figure 5-11

### DRAIN CLEANING

Check the drain from the dryer periodically to keep the drain clear to allow water or solvent etc. to drain freely. If the drain becomes plugged it will slow down the drying time.

To check and clean the drain remove the discharge outlet at A. Clean the drain area and reinstall the outlet.

**NOTE: Some dryers are equipped with screens at the drain outlet.**

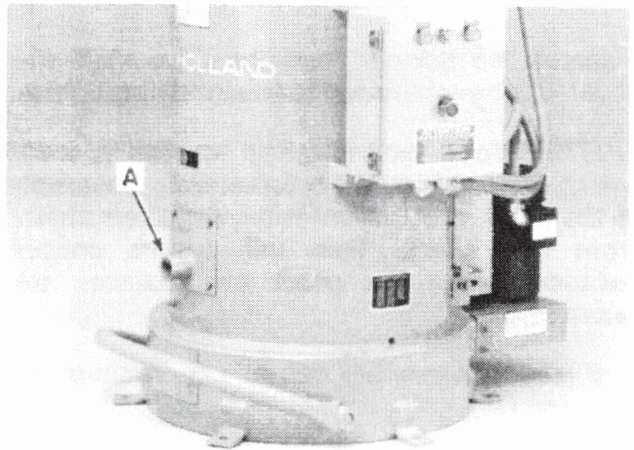

Figure 5-12

## BEARING REPLACEMENT

To replace the main spindle bearings.

Remove the lid from the dryer tube and remove the top ring A.

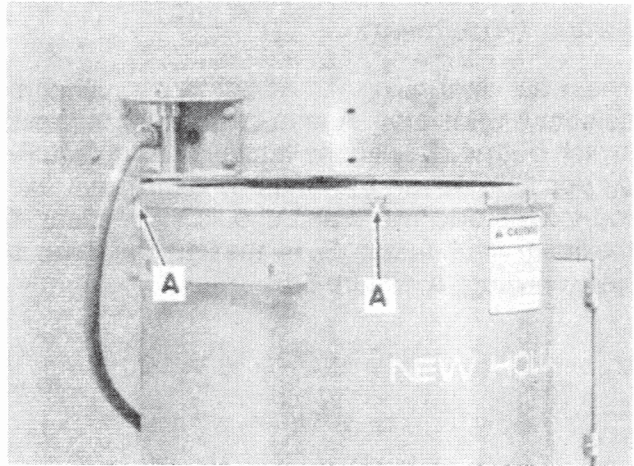

Figure 5-13

Remove the spinner from the drive shaft and dryer tube by removing the four retaining bolts A.

**NOTE: Before removing cap screws, A, mark the relationship of the spinner weld assembly to the shaft at B, before removing the spinner from the shaft. This will insure proper balance when the shaft and spinner are reassembled.**

The spinner assembly can now be removed as one unit.

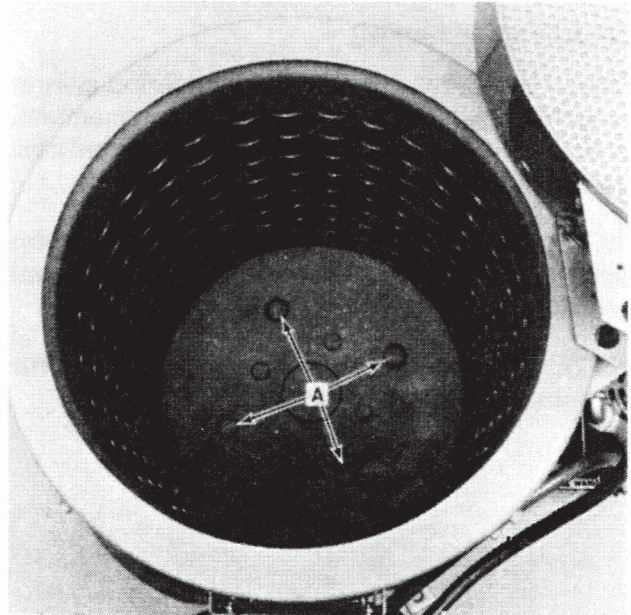

Figure 5-14



Remove the mounting bolts at the dryer base.

With a hoist lay the dryer on its side to access the drive belt and brake area.

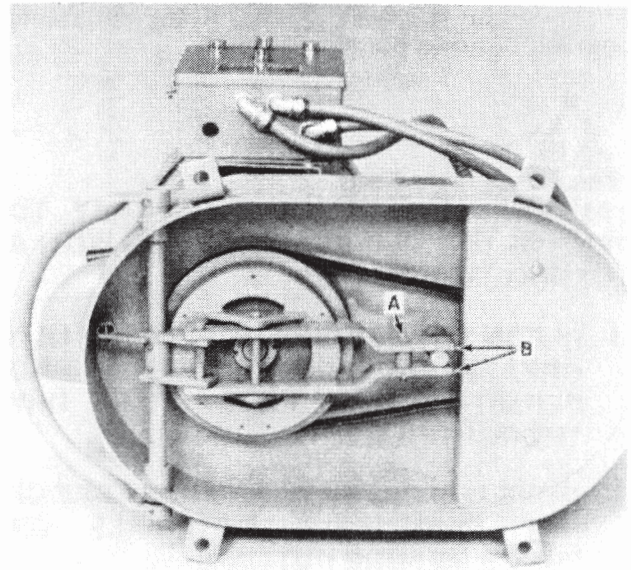

Figure 5-15

Loosen and remove the belts, see instructions in the "BELT REPLACEMENT" portion of this manual.

Remove the brake assembly. Remove the locknut, locking washer, sheave, key, seal, and bearing sleeve from the spindle shaft.

Remove the spindle shaft from the bearings with a 10 or 12 pound soft-faced driver. Protect the shaft threads and be careful not to damage threads in removal.

The K24 is shown in Figure 5-16.



**CAUTION: DO NOT DAMAGE THE THREADS ON THE SHAFT.**

**NOTE: The shaft must be driven through the bearings.**

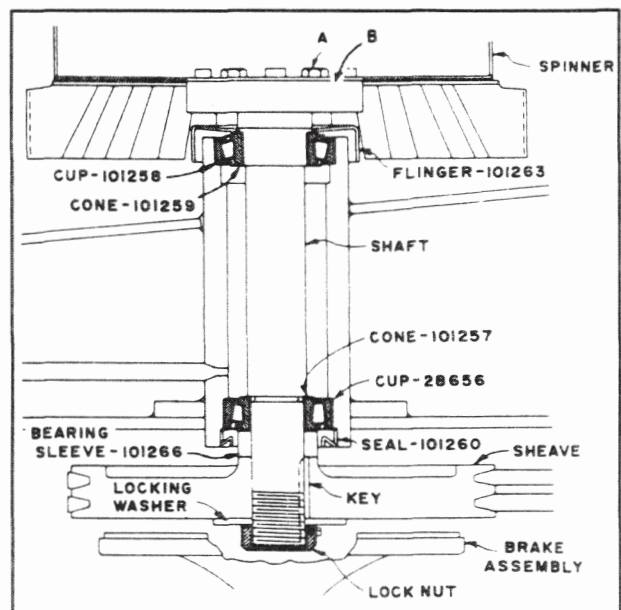

Figure 5-16

Replace the bearing cups when installing new cones. Clean out old grease and contaminants from the bearing housing area.



**CAUTION: IT MAY BE NECESSARY TO REMOVE THE OLD BEARING CUPS WITH A CUTTING TORCH.**

- 1. CLEAN THE BEARING HOUSING OF OLD GREASE AND CONTAMINANTS AND PERMIT THE AREA TO DRY THOROUGHLY.**
- 2. MOVE THE DRYER TO AN AREA FREE OF ANY FLAMMABLE MATERIALS OR FUMES BEFORE CUTTING.**
- 3. DO NOT DAMAGE THE BEARING HOUSING WITH THE CUTTING TORCH.**

Install the new cups being sure both are fully and squarely seated.

Install the new upper bearing on the shaft. Place the assembly in the housing and install the lower bearing.

**NOTE: For easier installation, install the new upper bearing on the shaft. Install the spinner assembly with the weld bead on the spinner turned 180° from the key in the spindle shaft. The dryer shaft and spinner were dynamically balanced at the factory. Reinstall in the same relationship as was noted and marked in disassembly. This procedure insures proper balance of the spinner and shaft weld assemblies.**

Set the spinner and shaft on the floor and using a hoist set the dryer down over the shaft and install the lower bearing.

Pack both bearings with a good grade of grease. See the "LUBRICATION" section. Fill the cavity between the bearings with grease, two 14oz. tubes are required. Install the lower bearing, bearing sleeve, sheave, and key.

Install a locking washer and nut or locknut and tighten until 2 lbs. to 6 lbs. of torque is required to turn the spindle shaft. Bend the locking washer tab if used, to hold the nut.

Install the spinner assembly if not installed earlier, with the weld bead on the spinner turned 180° from the key in the spindle shaft. The dryer shaft and spinner were dynamically balanced at the factory. Reinstall in the same relationship as was noted and marked in disassembly. This procedure insures proper balance of the spinner and shaft weld assemblies.

Install the belts and brake assembly.

Tighten the belts as detailed in the "BELT REPLACEMENT" and "BELT ADJUSTMENT" portions of this manual.

Reinstall the top ring and lid.

Reinstall any shields previously removed.

Bearing replacement kits can be ordered from New Holland. Order a #204815 kit for the K-24 and a #802350 kit for the K-90, K-90E, and K-94 dryers.



## SOFT-START MOTOR CONTROLLER ADJUSTMENT

Two sets of independent adjustments on the Series 25B allow the controller to be set for each application. The softness of the start is controlled by the setting of the Start Time and Initial Torque adjustments. An arrow on the face of the controller indicates the direction to rotate the adjustments to increase the starting time or torque (CW).

The New Holland dryer only uses one set indicated by the numbers, 1.

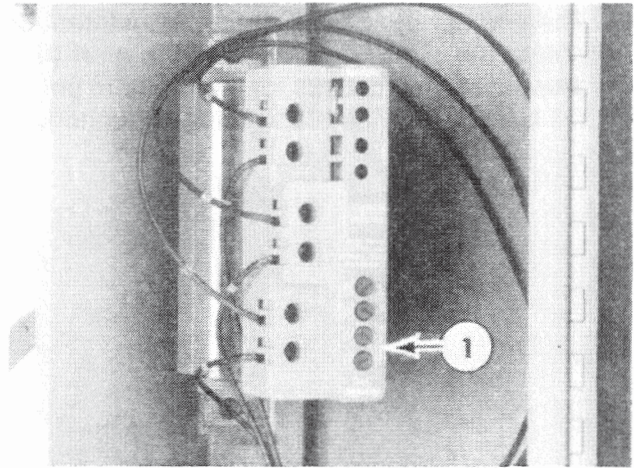

Figure 5-17

To set up the Ramp 1 adjustments for the best soft-start.

1. Rotate the Start Time, 2, adjustment for the longest time possible (fully clockwise - in the direction of the arrow).
2. Rotate the Initial Torque, 1, adjustment for the lowest starting voltage possible (fully counterclockwise - opposite the direction of the arrow).
3. Start the motor. When properly set, the motor shaft should start to rotate when the start button is pushed. If the motor does not start to rotate when the start button is pushed but is delayed for several seconds, turn the motor off and readjust the Initial Torque adjustment. Turn the adjustment slightly in the direction of the arrow to increase the initial starting voltage to the motor.
4. Restart the motor. Continue to adjust the Initial Torque adjustment until the motor starts turning when the start button is pushed.

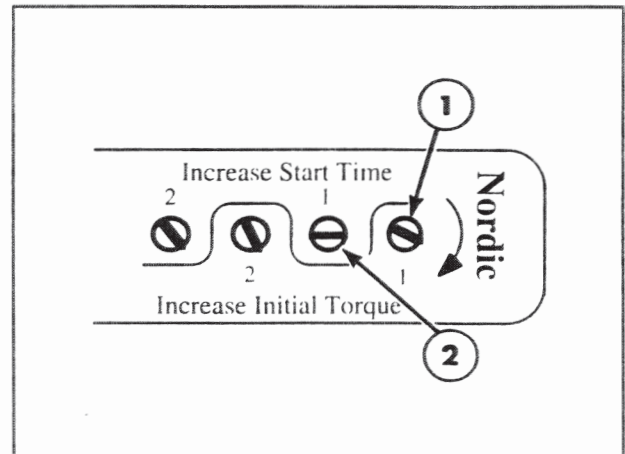

Figure 5-18

5. Then adjust the Start Time, 1, adjustment to obtain the desired duration of the start (the amount of time it takes for the motor to get to full speed after the start button is pushed).

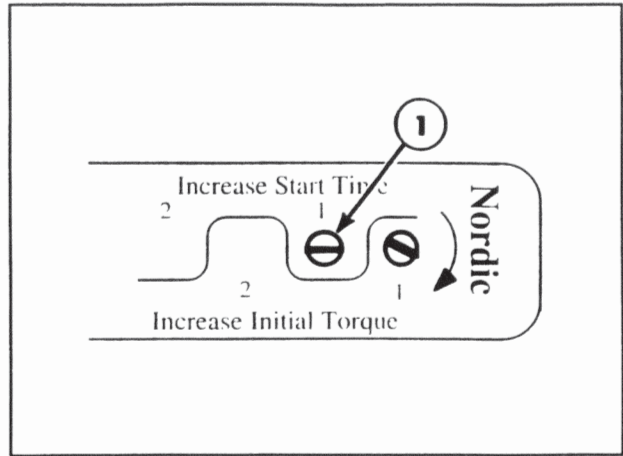

Figure 5-19

---

# SECTION 6

## TROUBLESHOOTING

If there is no power to the dryer control switches, check the electric power source to the dryer. Check the #262635 one-amp fuse in the control box.



**WARNING: ALWAYS HAVE A QUALIFIED ELECTRICIAN TROUBLESHOOT AND MAKE ALL NECESSARY REPAIRS.**

### INSPECTION

Occasionally inspect all wiring and components for wear or deterioration. Have a competent electrician replace any badly worn parts with materials of the same quality. Use of U.L. approved or recognized components is essential. Inspect the interior of the control box for any leakage of fluids into the box if dripping baskets or flats must be swung over the box. Oil-tight components are used by New Holland

and, if not disturbed, will repel dripping fluids if they inadvertently hit the box. Seal a leaking box using a silicone sealant such as Dow Corning Silastic (clear) 732 RTV, General Electric RTV 108, or an equivalent quality silicone bathtub sealant.



**WARNING: THE CONTROL BOX ASSEMBLY IS NOT WATERTIGHT, BUT DUST-TIGHT AND DRIP-TIGHT ONLY. IF THE PURCHASER FEELS HE MUST USE A WATERTIGHT BOX, HE SHOULD PURCHASE A "NEMA 4" BOX AND HAVE A QUALIFIED ELECTRICIAN INSTALL THE NEW HOLLAND COMPONENTS INTO THAT BOX, USING ONE OF THE RECOMMENDED SEALANTS AS REQUIRED TO INSURE A FULL WATER TIGHT SEAL AT ALL COMPONENT LOCATIONS.**

**CONTROL BOX COMPONENTS**

- 1 - Transformer
- 2 - Auxiliary contact (2 per dryer) electric heat only
- 3 - Contactor (2 per dryer)
- 4 - Interlock
- 5 - Fuse block(1 amp fuse)
- 6 - Terminal block
- 7 - Heater power relay (electric heat only)
- 8 - Overload relay
- 9 - Overload heaters (3 per dryer)
- 10 - Reverse switch
- 11 - Start/Stop switch
- 12 - Forward switch
- 13 - Electric heat switch

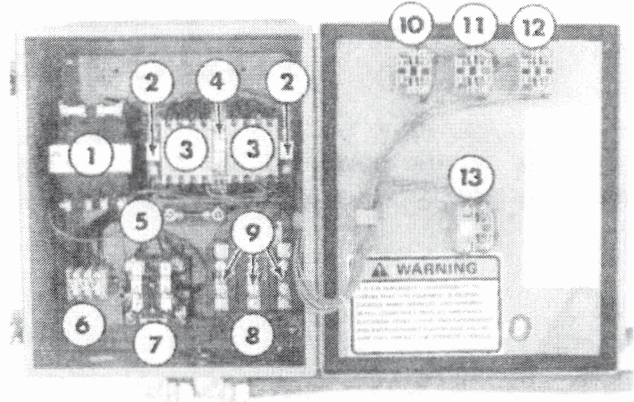

Figure 6-1

The dryers are equipped with an over load relay reference 8, part number #86508118 and three (3) heaters reference 9. Refer to the heater chart for the proper heaters to be used.

**OVERLOAD HEATER CHART**

NEW HOLLAND PART NUMBER	ALLAN BRADLY NUMBER	MOTOR LOAD AMPS. (BETWEEN)
86508402	B-30	1.30 - 1.42
86508128	B-32	1.57 - 1.71
86508129	B-36	2.28 - 2.50
86518141	B-39	3.03 - 3.32
86508130	B-40	3.33 - 3.64
86508403	B-42	4.01 - 4.40
86508405	B-44	4.85 - 5.31
86508131	B-46	5.85 - 6.42
86508132	B-50	8.10 - 8.94

1-amp fuse New Holland #262635



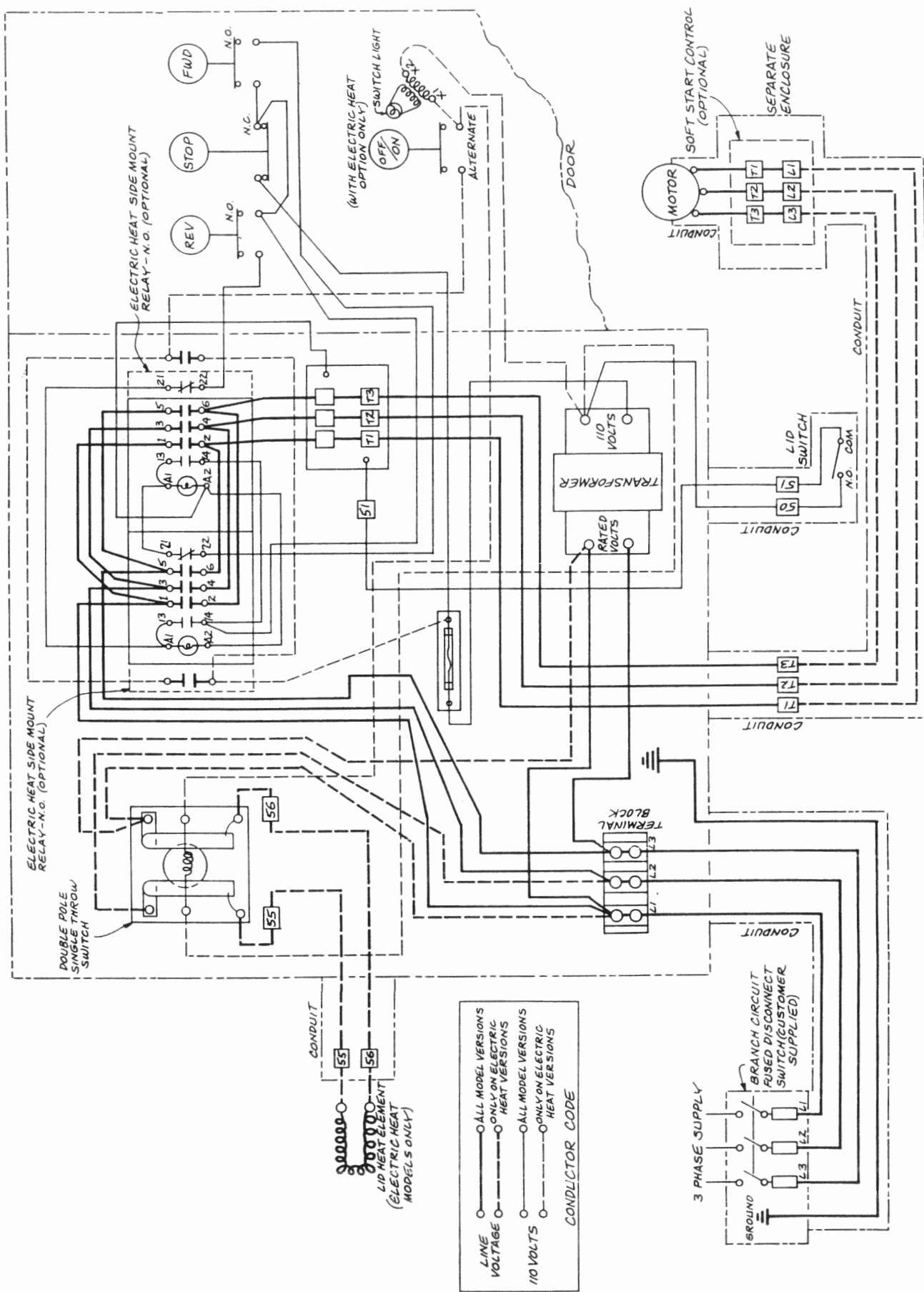



# SECTION 7

## SPECIFICATIONS

	<u>Model K-24</u>	<u>Model K-90</u>	<u>Model K-90E</u>	<u>Model K-94</u>
Overall Height . . . . .	36-1/2" (927 mm)	40-1/2" (1029 mm)	40-1/2" (1029 mm)	46-1/2" (1181 mm)
Work Height . . . . .	30-1/2" (775 mm)	37" (940 mm)	37" (940 mm)	43" (1092 mm)
Floor Spacing Required . . . . .	24" x 37" (610 mm x 940 mm)	31" x 40" (787 mm x 1016 mm)	31" x 40" (787 mm x 1016 mm)	31" x 40" (787 mm x 1016 mm)
Weight . . . . .	400 lbs. (181.4 kg)	615 lbs. (279 kg)	615 lbs. (279 kg)	690 lbs. (313 kg)
Operating Speed . . . . .	825 RPM	625 RPM	625 RPM	625 RPM
Motor Size . . . . .	1 hp (0.75 kw)	2 hp (1.5 kw)	2 hp (1.5 kw)	3 hp (2.25 kw)
Basket Size . . . . .	12" x 12" (305 mm x 305 mm)	18" x 18" (457 mm x 457 mm)	11-5/8" x 11-5/8" (295 mm x 295 mm)	18" x 24" (457 mm x 610 mm)
Capacity . . . . .	75 lbs. (34 kg)	150 lbs. (68 kg)	100 lbs. egg flats	250 lbs. (113 kg)
Bearings . . . . .	2 tapered roller	2 tapered roller	2 tapered roller	2 tapered roller
Grease Fittings . . . . .	Exposed	Exposed	Exposed	Exposed
Drive . . . . .	2 V-belts	2 V-belts	2 V-belts	2 V-belts
Construction . . . . .	Arc welded steel plate	Arc welded steel plate	Arc welded steel plate	Arc welded steel plate
Electrical System . . . . .	208, 220, 380 volt (50 Hz)	208, 220, 380 440 or 550 volt 3 phase	208, 220, 380 volt - 3 phase	208, 220, 380 440 or 550 volt 3 phase
Meets N.E.C. Specifications . . .	Yes	Yes	Yes	Yes
Reversible Control . . . . .	Yes - Reversing Switch	Yes - Reversing Switch	Yes - Reversing Switch	Yes - Reversing Switch
Optional Heating Units . . .	Electric; steam	Electric; steam	Electric	Electric; steam
Meets J.I.C. Specifications . . . .	Yes	Yes	Yes	No

---

# INDEX

Contents .....	0-3	Optional Electric Lid Heater .....	3-2
Warranty .....	Inside Front Cover	Operating the Dryer with the Electric Heating Unit (optional) .....	3-8
Owner Assistance .....	0-1	Operating the Dryer with the Steam Heating Unit (optional) .....	3-9
Safety .....	0-4	Soft-Start Motor Controller (optional) .....	3-2
Section 1 - General Information .....	1-1	Section 4 - Lubrication .....	4-1
Chip-wringer K-24, K-90, K-94 .....	1-3	Dryer Motor .....	4-1
K-24 Dryer .....	1-1	Main Bearings .....	4-1
K-90 Dryer .....	1-1	Section 5 - Adjustments and Maintenance ...	5-1
K-90E Dryer .....	1-2	Adjusting and Replacing Belts .....	5-2
K-94 Dryer .....	1-2	K-90, K-90E, K-94 Belt Adjustment .....	5-2
Section 2 - Installation .....	2-1	K-90, K-90E, K-94 Belt Replacement ...	5-2
Dryer Installation .....	2-9	Bearing Replacement .....	5-6
Dryer Location .....	2-1	Drain Cleaning .....	5-5
Floor Preparation .....	2-8	Lid Adjustment .....	5-3
Floor Support Frame .....	2-5	Soft-Start Motor Controller Adjustment ...	5-9
Floor Frame Assembly K-24 .....	2-6	Section 6 - Troubleshooting .....	6-1
Floor Frame Assembly K-90, K-90E, K-94	2-7	Control Box Components .....	6-2
Heaters (optional) .....	2-9	Inspection .....	6-1
K-90, K-90E, K-94 Installation .....	2-2	Overload Heater Chart .....	6-2
Section 3 - Operation .....	3-1	Section 7 - Specifications .....	7-1
Chip-Wringer Operation .....	3-6	To The Owner .....	0-2
Controls .....	3-1		
Dryer Capacity .....	3-9		
K-90E Egg Flat Dryer Operation .....	3-7		
Operating the Dryer .....	3-3		





TRUSTED NAMES IN EQUIPMENT

# SERVICE PARTS

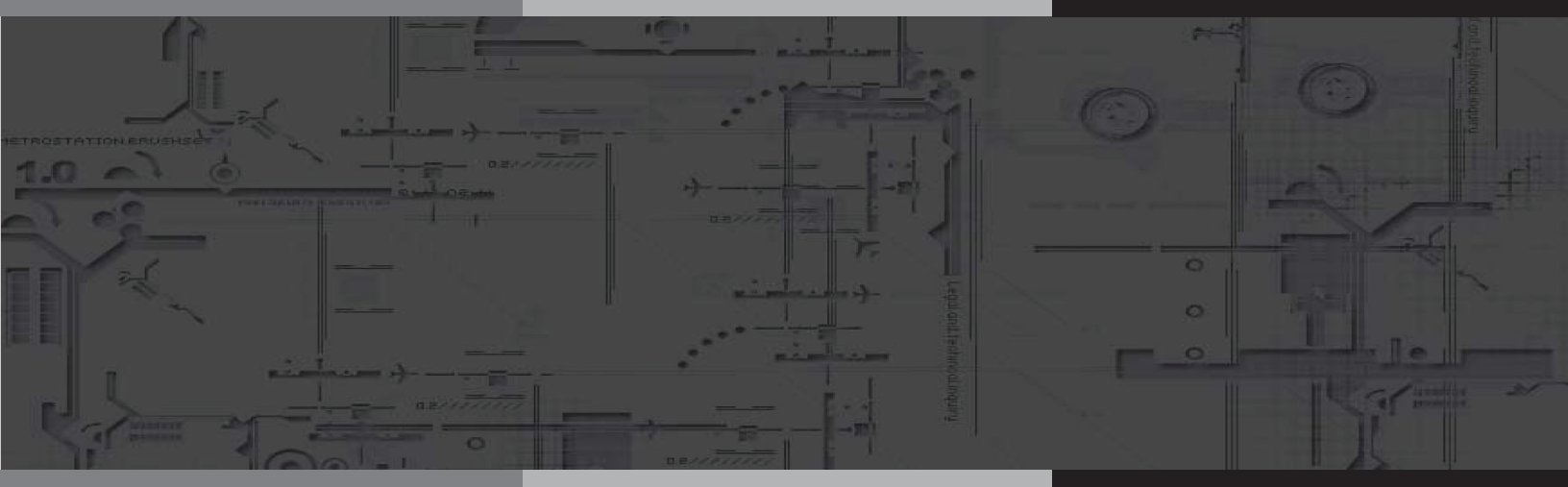



**HOUSING & DRYER DRIVE**

REF	FN	PART NUMBER	YR/SN	QTY	DESCRIPTION
1		196029		1	Ring
		690341		4	Screw, Self-Tapping, Flg, USR, 5/16"-18 x 5/8"
2		9602076		AR	Basket, Carbon Steel, 4 x 4, K-90
2		9809333		AR	Basket, Carbon Steel, Drop Bottom, 4 x 4, K-90
2		9602077		AR	Basket, Carbon Steel, 8 x 8, K-90
2		9602078		AR	Basket, Carbon Steel, 10 x 10, K-90
2		9809334		AR	Basket, Carbon Steel, Drop Bottom, 10 x 10, K-90
2		9602079		AR	Basket, Carbon Steel, 16 x 16, K-90
2		9602072		AR	Basket, Stainless Steel, 4 x 4, K-90
2		9809335		AR	Basket, Stainless Steel, Drop Bottom, 4 x 4, K-90
2		9602073		AR	Basket, Stainless Steel, 8 x 8, K-90
2		9602074		AR	Basket, Stainless Steel, 10 x 10, K-90
2		9809336		AR	Basket, Stainless Steel, Drop Bottom, 10 x 10, K-90
2		9602075		AR	Basket, Stainless Steel, 16 x 16, K-90
2		9862726		AR	Basket, E-Z Dump, Carbon Steel, 8 x 8, K-90
2		9862727		AR	Basket, E-Z Dump, Carbon Steel, 10 x 10, K-90
2		9862728		AR	Basket, E-Z Dump, Stainless Steel, 4 x 4, K-90
2		9862729		AR	Basket, E-Z Dump, Stainless Steel, 10 x 10, K-90
2		9863899		AR	Basket, Polypropylene, 3/16" Perforations, K-90
2		9863900		AR	Basket, Polypropylene, .015" Openings, K-90, W/#40 Mesh Line
2		9804003		AR	Basket, Carbon Steel, 4 x 4, K-94
2		9804004		AR	Basket, Carbon Steel, 8 x 8, K-94
2		9804005		AR	Basket, Carbon Steel, 10 x 10, K-94
2		9804006		AR	Basket, Carbon Steel, 16 x 16, K-94
2		9803999		AR	Basket, Stainless Steel, 4 x 4, K-94
2		9804000		AR	Basket, Stainless Steel, 8 x 8, K-94
2		9804001		AR	Basket, Stainless Steel, 10 x 10, K-94
2		9804002		AR	Basket, Stainless Steel, 16 x 16, K-94
2		9862747		AR	Basket, E-Z Dump, Carbon Steel, 4 x 4, K-94
2		9862730		AR	Basket, E-Z Dump, Carbon Steel, 10 x 10, K-94
2		9862731		AR	Basket, E-Z Dump, Stainless Steel, 4 x 4, K-94
2		9862732		AR	Basket, E-Z Dump, Stainless Steel, 10 x 10, K-94
2		9863899		AR	Basket, 3/16, Poly, K90
2		9863900		AR	Basket, Poly, W/#40 Liner, K-90
2		9863901		AR	Basket, Polypropylene, 3/16" Perforations, K-94

**K90 K90E K94**



HOUSING & DRYER DRIVE

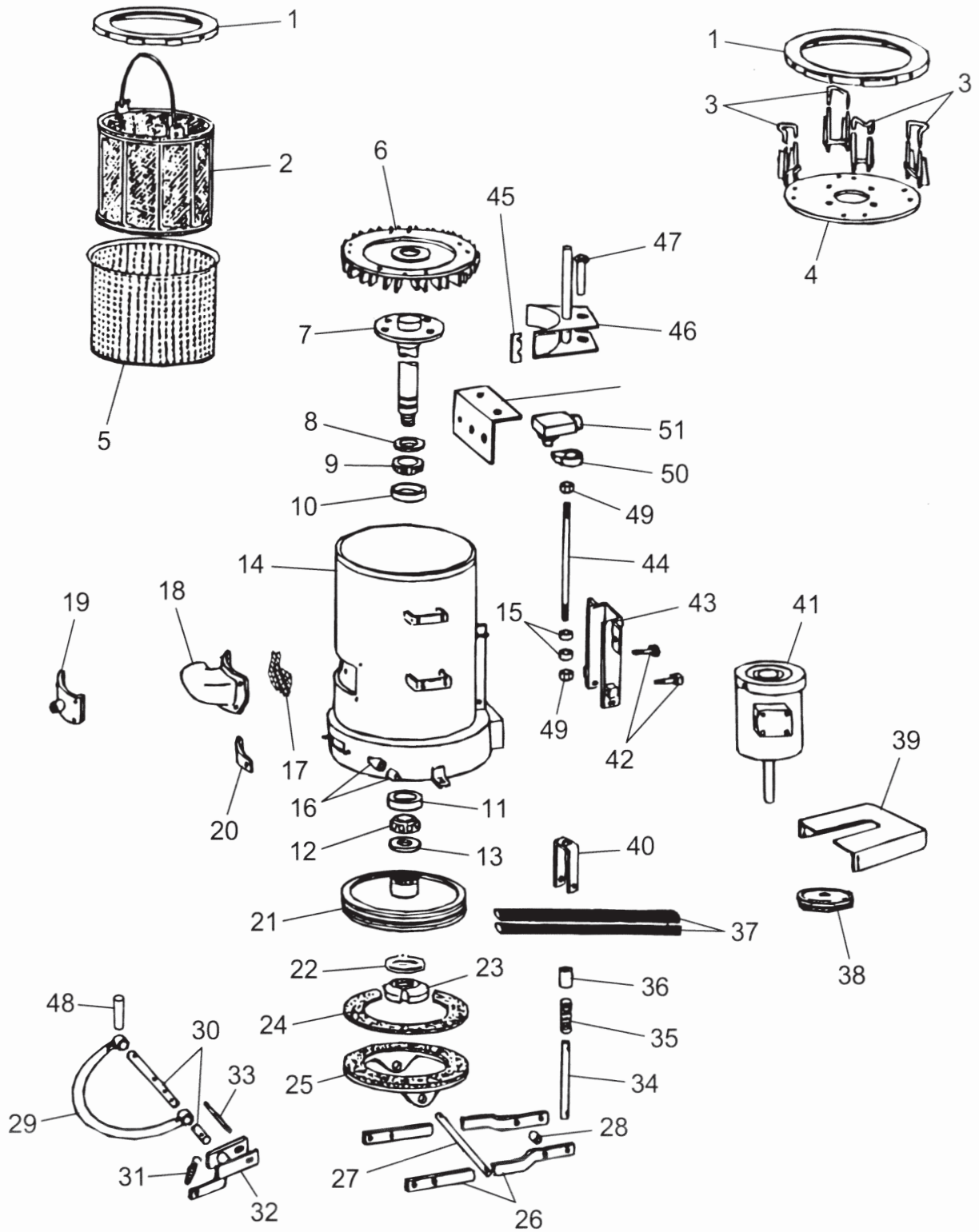

**HOUSING & DRYER DRIVE**

REF	FN	PART NUMBER	YR/SN	QTY	DESCRIPTION
2		9863902		AR	Basket, Polypropylene, .015" Openings, K-94, W/#40 Mesh Liner
3		719732		4	Retainer Weld Assy., K-90E
4		719729		1	Base, Spinner, K-90E
		280580		4	Screw, Cap, HH, G5, 5/8"-11 x 1"
5		9802904		1	Spinner, K-94
		280580		4	Screw, Cap, HH, G5, 7/16" x 1"
		719744		1	Spinner, K-90
		280580		4	Screw, Cap, HH, G5, 5/8"-11 x 1"
6		719730		1	Turbine
		88574		3	Screw, Cap, HH, G5, 5/16"-18 x 1/2", K-90,K-94
		88902		1	Nut, Lock, GC, 3/8"-16
		80681		3	Washer, Lock, 5/16", K-90, K-94
		88902		1	Nut, Lock, GC, 3/8"-16
7		147231		1	Drive Shaft
		280580		4	Screw, Cap, HH, G5, 5/8"-11 x 1"
8		147212		2	Flinger
9		147214		1	Cone, Bearing, Tapered Roller, Timken #JHM-318448
10		147213		1	Cup, Bearing, Tapered Roller, Timken JHM-318410
11		9617935		1	Cup, Bearing, Tapered Roller, Timken #JM-515610
12		147216		1	Cone, Bearing, Tapered Roller, Timken #JM-515649
13		147229		1	Seal, Oil
14		254323		1	Housing, K-90, K-90E Includes: (2) Ref. 15 & 16
14		636717		1	Housing, K-90, K-90E Includes: (2) Ref. 15 & 16, Does Not Require Ref. 20
14		9802886		1	Housing, K-94 Includes: (2) Ref. 15 & 16
		147233		1	Nipple, Pipe, 1/8" x 7-1/2"
		91932		1	Coupling, Pipe, 1/8"
		80710		1	Fitting, Nipple, Lube, 1/8"
		87569		2	Fitting, Lube, 1/4"-45°
15		27767		2	Bushing
16		34235		2	Bushing
17		101253		1	Screen
18		184257		1	Elbow, Exhaust, K-90,K-94
		280519		4	Screw, Self-Tapping, Type B, HH, 5/16" x 1"
19	1	218522		1	Plate

(1) Standard on K-90E Only. Optional on other models through Service Parts

	<b>K90 K90E K94</b>
--	---------------------

HOUSING & DRYER DRIVE

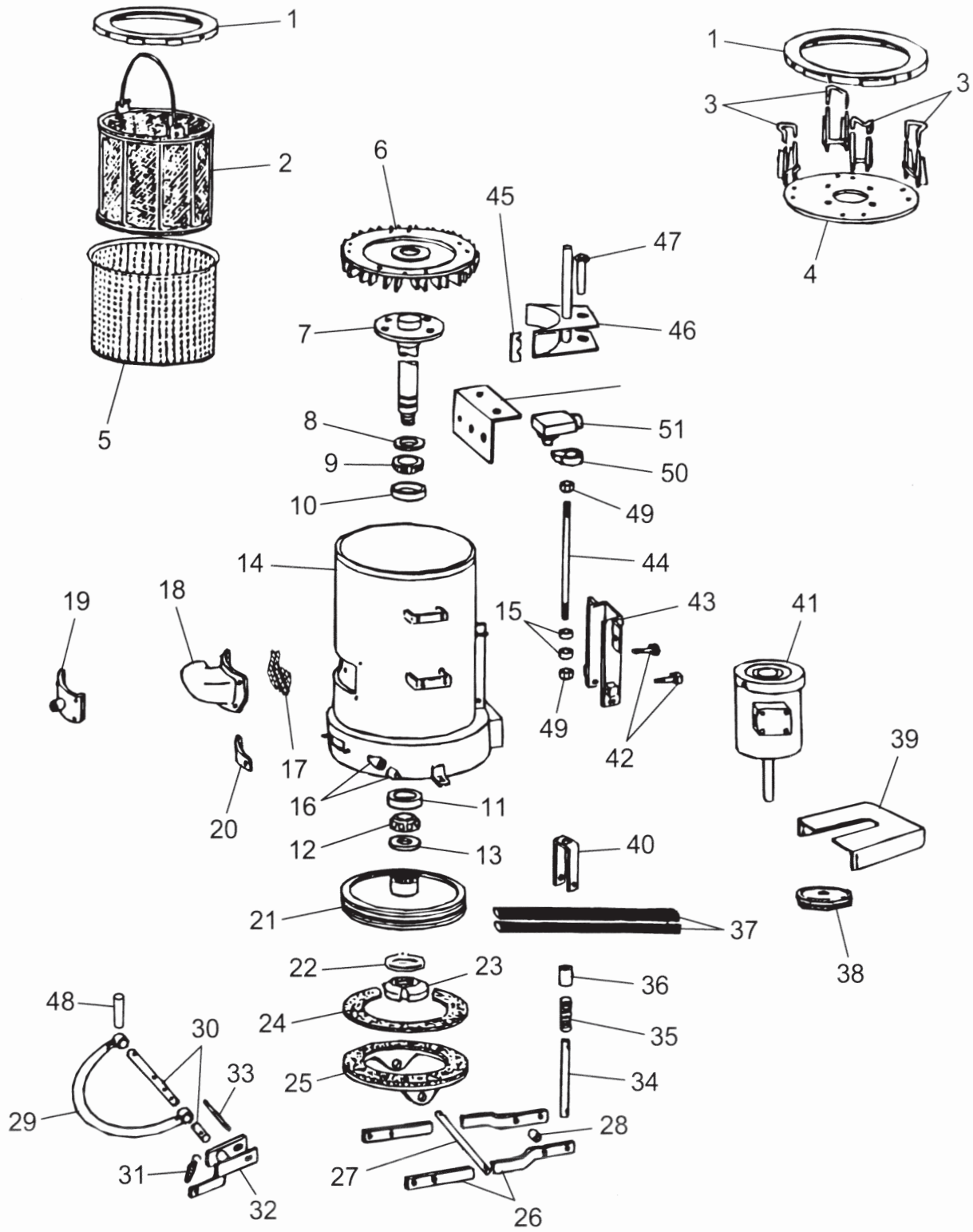



**HOUSING & DRYER DRIVE**

REF	FN	PART NUMBER	YR/SN	QTY	DESCRIPTION
		80679		8	Washer, Lock, 1/2"
		280519		4	Screw, Self-Tapping, Type B, HH, 5/16" x 1"
		280431		8	Nut, G5, 1/2"-13
20		147236		1	Cover
		80681		2	Washer, Lock, 5/16"
		80801		2	Nut, Wing, 5/16"-18
21		147223		1	Sheave, Driven
		788386		1	Key, Sheave
22		52706		1	Washer, Hardened
23		101262		1	Nut, Lock, Bearing
		80426		1	Screw, Set, HS, Cup Pt, 3/8"-16 x 5/16"
24		9601493		1	Lining, Brake
		80245		7	Rivet, Flat Hd., Tubular, 3/16" x 1/2"
25		101245		1	Shoe, Brake Includes: Ref. 24
26		184246		2	Link
27		101270		1	Pin, Brake Pivot
		80755		2	Pin, Split Cotter, 1/8" x 1"
28		143274		1	Spacer
		87936		1	Screw, Cap, HH, G5, 3/8"-16 x 2-1/2"
29		184254		1	Lever
		87569		2	Fitting, Lube, 1/4"-45°
		87718		2	Pin, Roll, 1/4" x 2"
30		184249		1	Shaft, Brake Lever Totally Enclosed
		87718		2	Pin, Roll, 1/4" x 2"
31		676397		1	Spring
32		101238		1	Yoke, Brake
33		101271		1	Pin, Yoke Pivot
		80755		2	Pin, Split Cotter, 1/8" x 1"
34		147102		1	Shaft
		87949		1	Pin, Roll, 3/8" x 1-3/4"
35		6132		1	Spring
36		101248		1	Guard, Spring Interlock
37		849889		1	V-Belt, Matched Set of (2), K-90,K-90E
37		9802891		1	V-Belt, Matched Set of (2), K-94
38		216740		1	Sheave, Motor
		88528		1	Screw, Set, Sq Hd, Knurled Pt, 5/16"-18 x 3/8"
		87476		1	Key, Machine, Square, 3/16" x 1-1/2"

**K90 K90E K94**

HOUSING & DRYER DRIVE

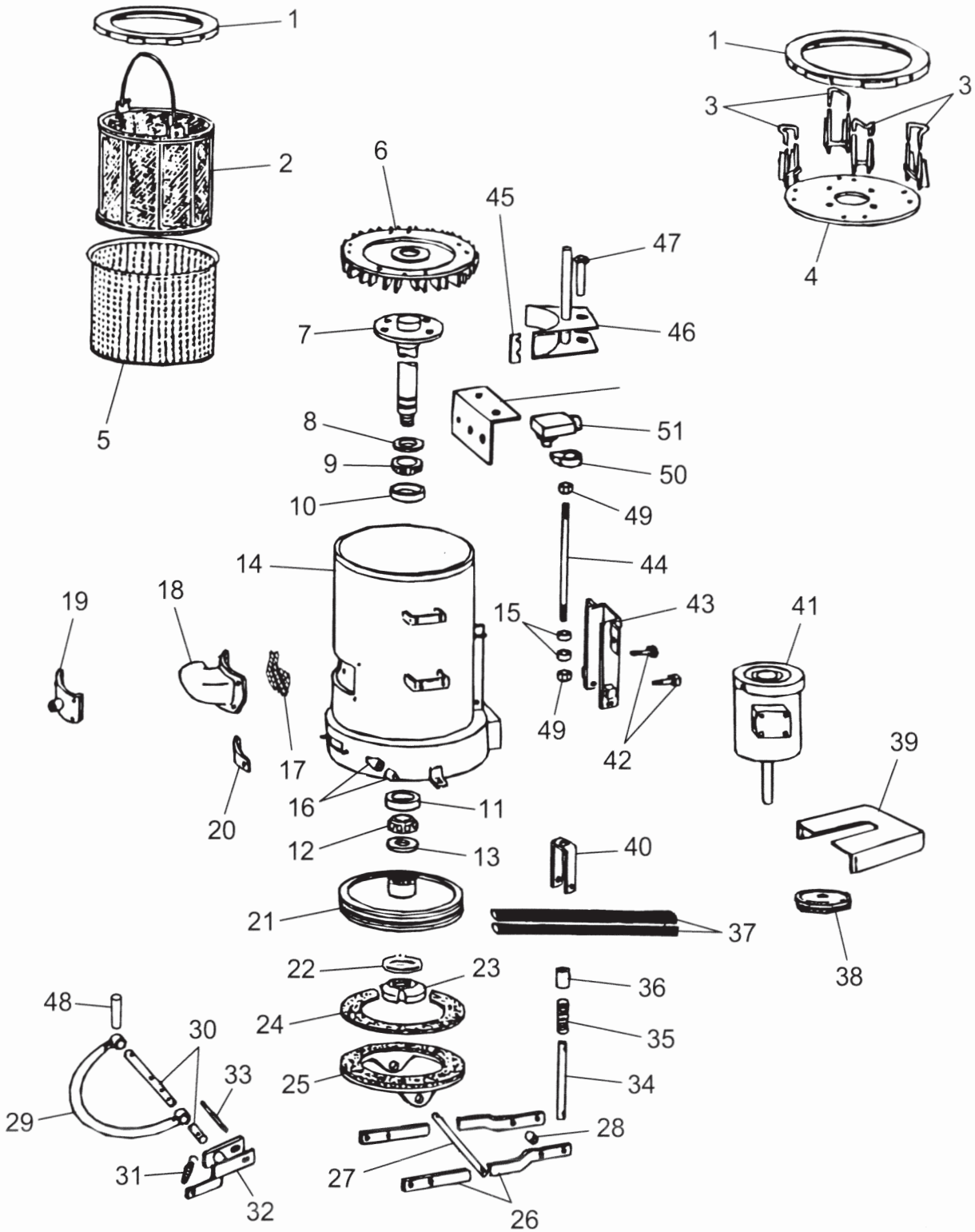

**HOUSING & DRYER DRIVE**

REF	FN	PART NUMBER	YR/SN	QTY	DESCRIPTION
39		184272		1	Shield, Motor Sheave
		88992		4	Bolt, Carriage, Short Neck, G5, 5/16"-18 x 1"
		80664		4	Washer, 5/16"
		80681		4	Washer, Lock, 5/16"
		88206		4	Screw, Cap, HH, G5, 3/8"-16 x 1"
40		147100		1	Clevis
		88402		1	Screw, Cap, HH, G5, 3/8" x 1-3/4"
41		242217		1	Motor, Electric, 2 HP, 208/280/460 Volt, 3 Phase, Totally Enclosed, K-90,K-90E
41		700284		1	Motor, Electric, 2 HP, 200/208V, 3 Phase, Totally Enclosed, K-90,K-90E
41		242219		1	Motor, Electric, 2 HP, 380V, 50 HZ, 3 Phase, Totally Enclosed, K-90,K-90E
41		242215		1	Motor, Electric, 2 HP, 575V, 3 Phase, Totally Enclosed, K-90
41		9802888		1	Motor, Electric, 3 HP, 208/203/406V, 3 Phase, 60 Cycle, 1725 RPM, Totally Enclosed, K-94
41		9802889		1	Motor, Electric, 3 HP, 380V, 3 Phase, 50 Cycle, 1725 RPM, Totally Enclosed, K-94
41		9802887		1	Motor, Electric, 3 HP, 575V, 3 Phase, 60 Cycle, 1725 RPM, Totally Enclosed, K-94
		88992		4	Bolt, Carriage, Short Neck, G5, 5/16"-18 x 1"
		80664		4	Washer, 5/16"
		80681		4	Washer, Lock, 5/16"
		9635082		4	Nut, G5, 5/16"-18
42		86512813		2	Screw, Set, Sq Hd, Cup Pt, 3/8" x 3"
		9628503		2	Nut, G5, 3/8"-16, 1725 RPM, Totally Enclosed, K-94
43		242980		1	Channel, K-90,K-90E
43		9802903		1	Channel, K-94
		80702		4	Washer, 3/8"
		80680		4	Washer, Lock, 3/8"
44		181259		1	Rod, K-90,K-90E
44		9802901		1	Rod, K-94
		9638005		2	Nut, Jam, G2, 1/2"-13
45		680133		AR	Shim
46		181264		1	Pivot
		9635884		4	Screw, Cap, HH, G5, 5/16"-18 x 1"

**K90 K90E K94**



HOUSING & DRYER DRIVE

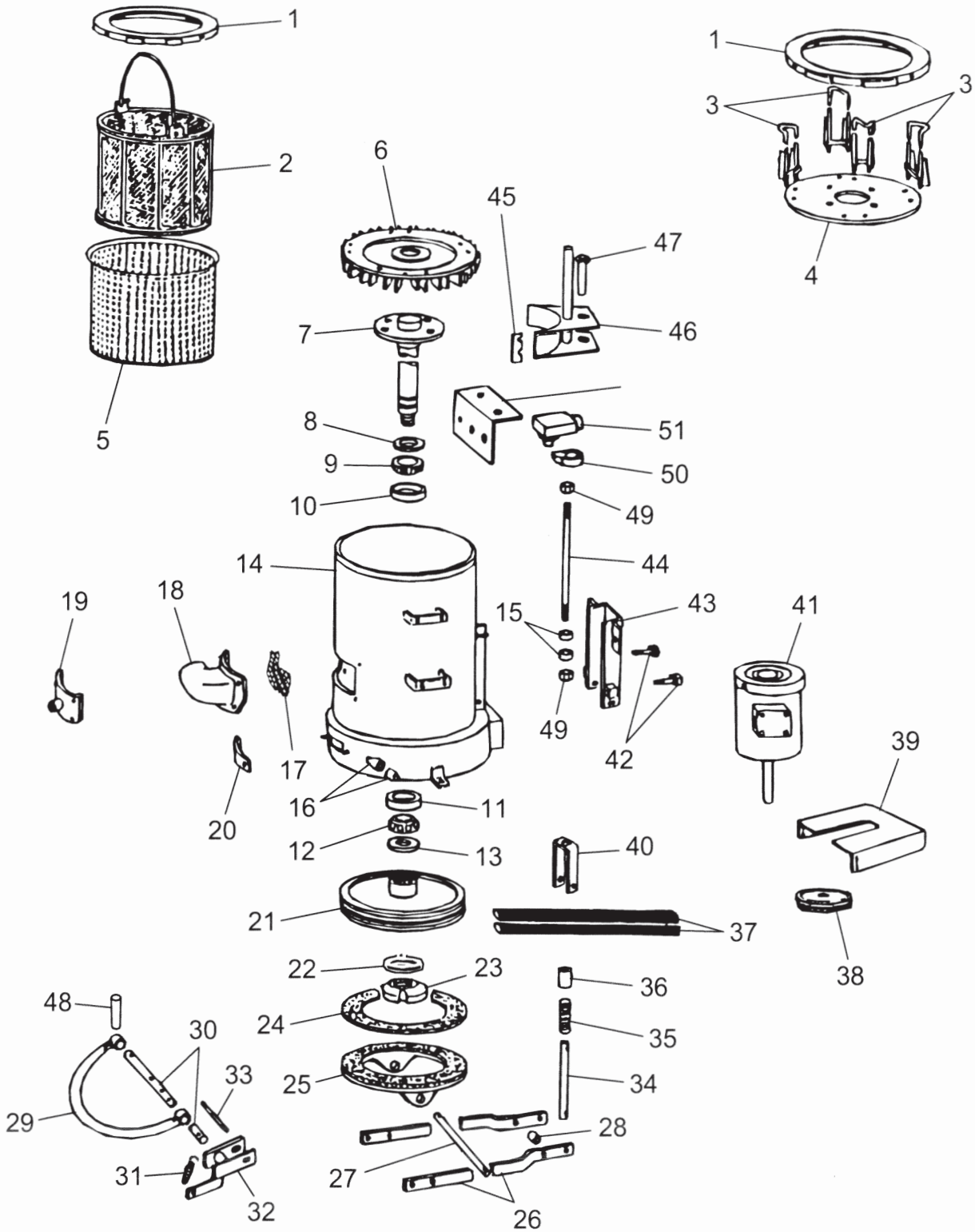

**HOUSING & DRYER DRIVE**

REF	FN	PART NUMBER	YR/SN	QTY	DESCRIPTION
		87362		4	Washer, SAE, 5/16"
		80681		4	Washer, Lock, 5/16"
47		184354		1	Rod
48		87718		4	Pin, Roll, 1/4" x 2"
49		9638005		2	Nut, Jam, G2, 1/2"-13
50		101268		1	Stop, Limit
		81761		1	Screw, Set, Sq Hd, Cup Pt, 1/4"-20 x 5/16"
51		101304		1	Switch, Limit Safety
		88363		2	Screw, Fillister Hd, G2, #6 x 1-1/4"
52		699767		1	Mount
		88565		2	Screw, Machine, HWH, #8-32 x 1-1/4"
		87812		2	Washer, Lock, #8
		87653		2	Nut, #8-32

	<b>K90 K90E K94</b>
--	---------------------

CONTROL BOX & CABLES

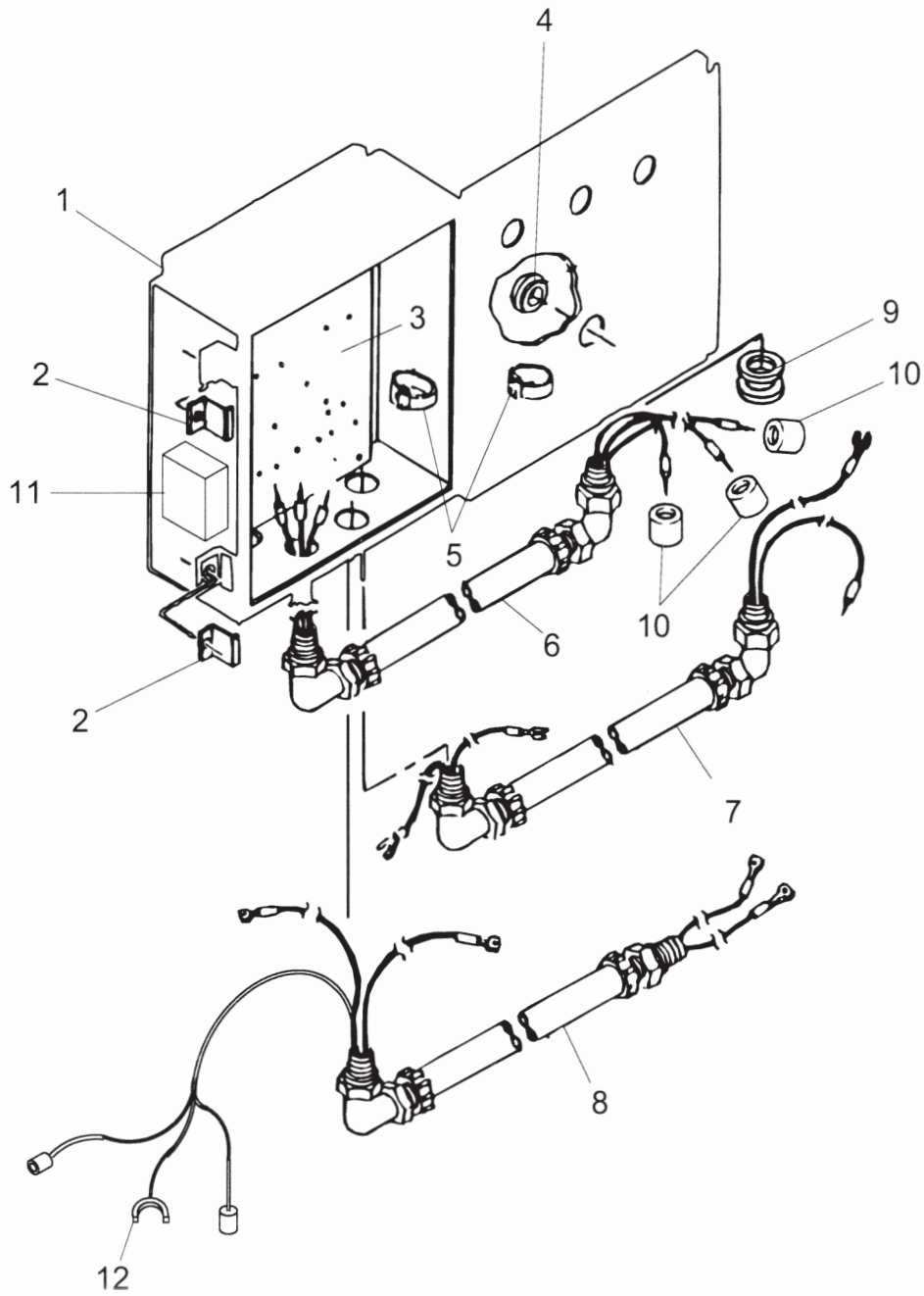

**CONTROL BOX & CABLES**

REF	FN	PART NUMBER	YR/SN	QTY	DESCRIPTION
1		855058		1	Control Box & Lid, Includes: Ref. 2
		80701		4	Washer, 1/4"
		80682		4	Washer, Lock, 1/4"
2		NSS		2	Clamp, Door
3		855056		1	Plate, Mounting, Controls, Refer to Separate Breakdown for Electrical Components
4		855070		1	Plug, Panel, 7/8", Used to Plug Hole on Non-Heated Units
5		855055		2	Grip, Wire
6		9609479		1	Cable, Motor
		86624388		1	Cable, Motor, Soft Start Controls
7		855054		1	Cable, Switch
8	1	263061		1	Cable, Heater,
9		101319		1	Washer, Reducing, Motor Cable
10		145300		6	Connector, Wire, Pigtail
		9707580		4	Screw, Cap, HH, G5, 1/4"-20 x 3/4"
		7770		4	Nut, G5, 1/4"-20
11		9862265		1	Timer, Kit
12	2	86529636		1	Sensor, Included with Temperature Control Kit 86529635

- (1) Used W/Electrically Heated Units Only
- (2) Electrically Heated Units Only

**K90 K90E K94**



CONTROL PANEL ELECTRICAL COMPONENTS, USED ON K-90 BSN 897094; K-90E BSN 886579; K-94 BSN 883813

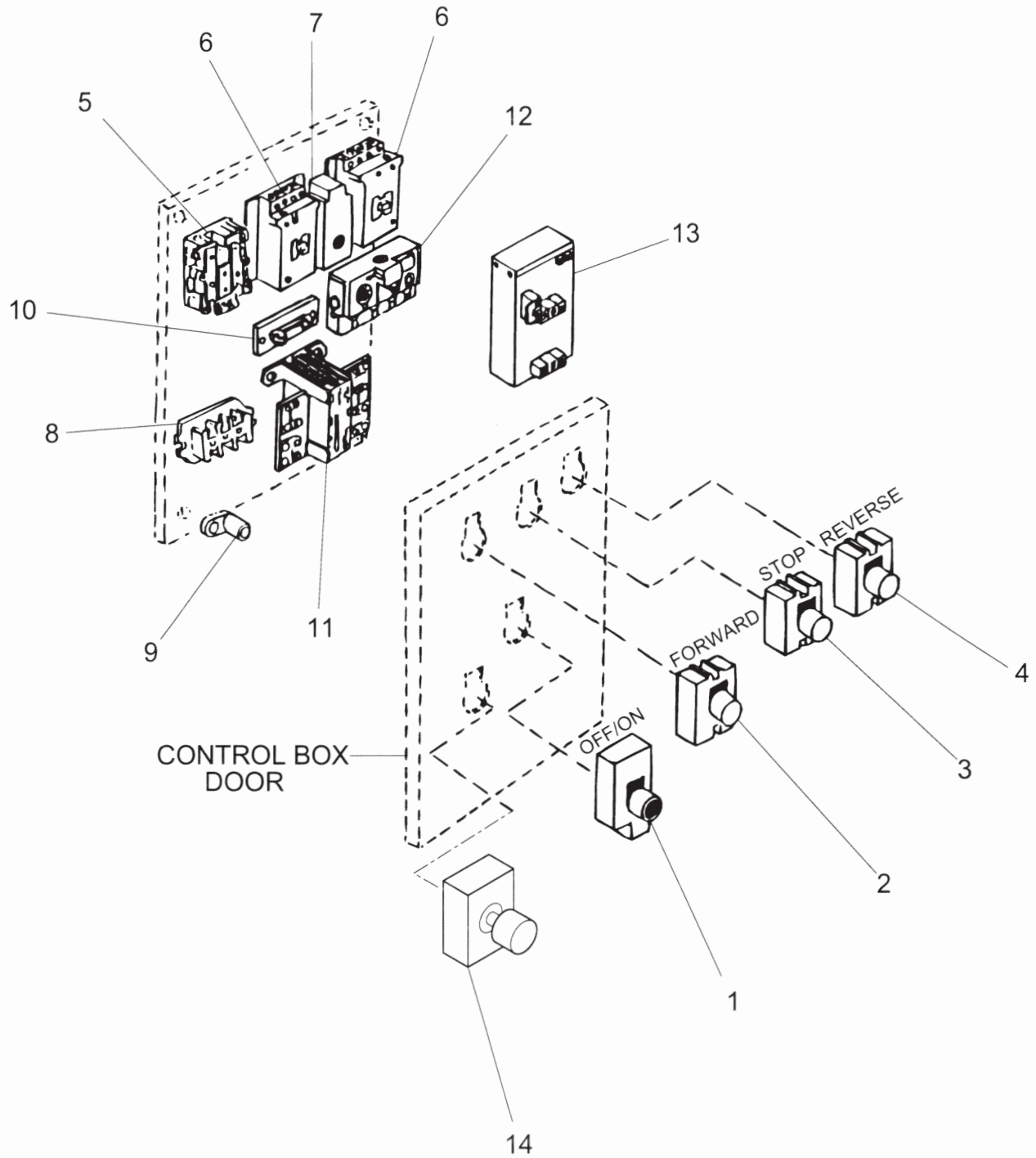

**CONTROL PANEL ELECTRICAL COMPONENTS, USED ON K-90 BSN 897094; K-90E BSN 886579; K-94 BSN 883813**

REF	FN	PART NUMBER	YR/SN	QTY	DESCRIPTION
1	1	855069		1	Switch, Push-Button, Off/On
2		855066		1	Switch, Push-Button, Forward
3		855067		1	Switch, Push-Button, Stop
4		855068		1	Switch, Push-Button, Reverse
5	1	855052		1	Relay, Power
		281020		2	Screw, Self-Tapping, Pan Hd, #8 x 3/4"
6		855050		2	Contactor
		281020		2	Screw, Self-Tapping, Pan Hd, #8 x 3/4"
7		855051		1	Contactor, Interlock
		280528		1	Screw, Self-Tapping, Plated, Oval Hd., #8 x 3/4"
8		254321		1	Block, Terminal
		87654		2	Screw, Self-Tapping, Rd Hd, #8 x 1/2"
9		141360		1	Lug, Ground
		86544338		1	Washer, Lock, Int-Ext T, #10
10		593526		1	Block, Fuse
		262635		1	Fuse, 1 Amp
		281076		1	Screw, Self-Tapping, Oval Hd, #6 x 5/8"
11		855042		1	Transformer, Control, 208/380 VAC
		855043		1	Transformer, Control, 240/480/600 VAC
12		855062		1	Relay, Overload, Adjusting Range, 2.0 - 3.2 Amps, K-90
12		855063		1	Relay, Overload, Adjusting Range, 3.0 - 5.0 Amps
12		855064		1	Relay, Overload, Adjusting Range, 4.5 - 7.5 Amps
12		9804202		1	Relay, Overload, 12 Amps
12		9621678		1	Relay, Overload, Class 20, W/Soft Start Controls, K-90
13		86507411		1	Control, Soft Start, 200/230 VAC
13		86507412		1	Control, Soft Start, 460/575 VAC
14		86529635		1	Control, Temperature, Includes Sensor, 86529636

(1) Electrically Heated Units Only

**K90 K90E K94**

CONTROL PANEL ELECTRICAL COMPONENTS, USED ON K-90 ASN 897093; K-90E & ASN 886578; K-94 ASN 883812

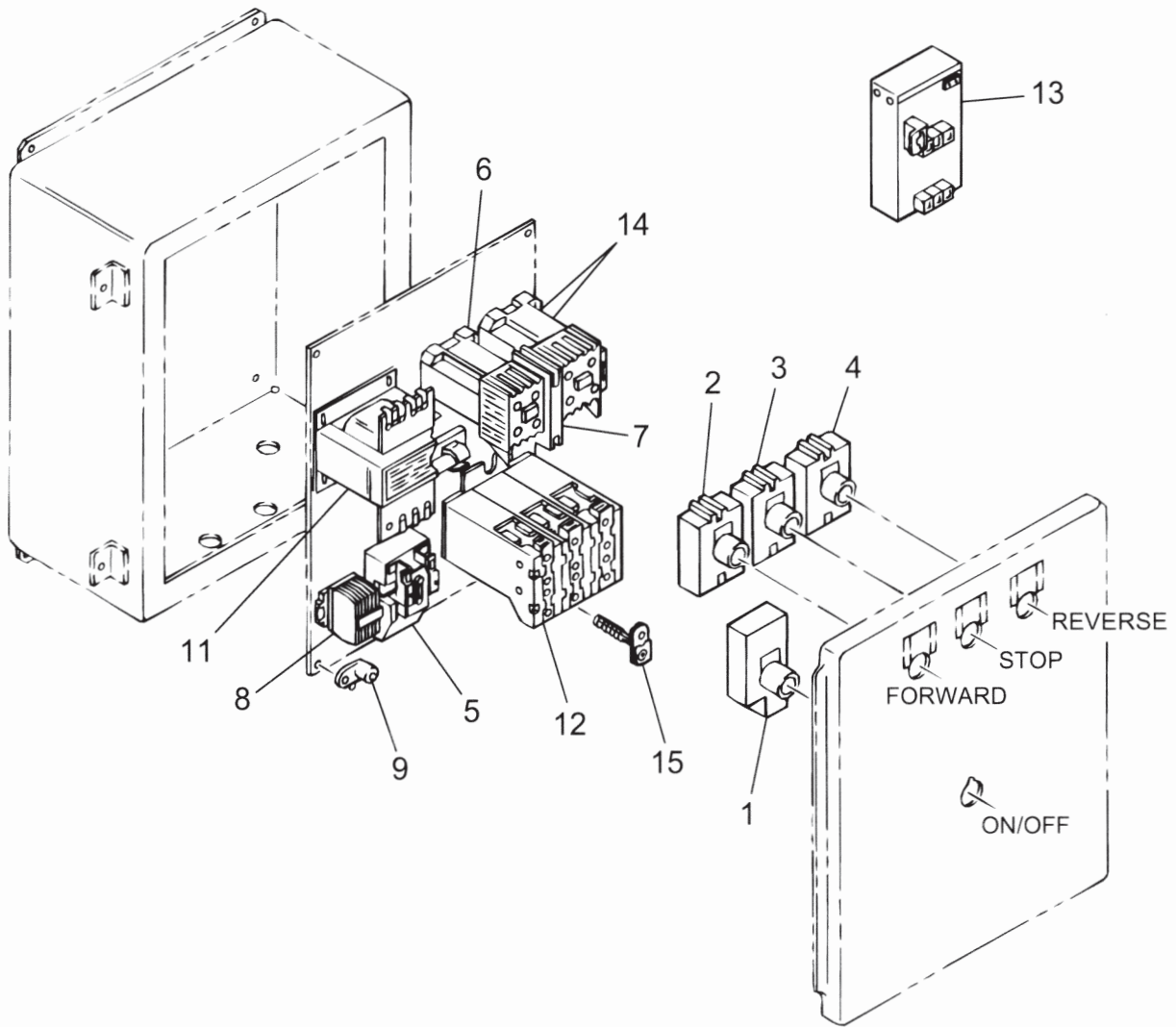

## CONTROL PANEL ELECTRICAL COMPONENTS, USED ON K-90 ASN 897093; K-90E &amp; ASN 886578; K-94 ASN 883812

REF	FN	PART NUMBER	YR/SN	QTY	DESCRIPTION
1	1	855069		1	Switch, Push-Button, Off/On
2		855066		1	Switch, Push Button, Forward
3		855067		1	Switch, Push Button, Stop
4		855068		1	Switch, Push Button, Reverse
5	1	855052		1	Relay, Power
		281020		2	Screw, Self-Tapping, Pan Hd, #8 x 3/4"
6	2	86508117		2	Contactors
6	3	86586797		2	Contactors
		281020		2	Screw, Self-Tapping, Pan Hd, #8 x 3/4"
7	2	86508116		1	Contactors, Interlock
7	3	86586797		1	Contactors
		280528		1	Screw, Self-Tapping, Plated Oval Hd., #8 x 3/4"
8		254321		1	Block, Terminal
		87654		2	Screw, Self-Tapping, Rd Hd, #8 x 1/2"
9		141360		1	Lug, Ground
		86544338		1	Washer, Lock, Int-Ext T, #10
10		593526		1	Block, Fuse
		262635		1	Fuse, 1 Amp
		281076		1	Screw, Self-Tapping, Oval Hd, #6 x 5/8"
11		855042		1	Transformer, Control, 208/380 VAC
11		855043		1	Transformer, Control, 240/480/600 VAC
12	2	86508118		1	Overload Relay
12	3	86586801		1	Overload Relay, 5 AMP
12	3	86586802		1	Overload Relay, 12 AMP
13		86624371		1	Control, Soft Start, 200/230 VAC
13		86624372		1	Control, Soft Start, 460/575 VAC
14	1,2	86508125		1	Contact, Auxiliary
14	1,3	86586799		2	Contact, Auxiliary
15	4	86508129		3	Heater, 2.50 Amp, Use W/575 VAC K-90
15	4	86508130		3	Heater, 3.64 Amp, Use W/380 VAC K90, 460 VAC K-90E, 575 VAC K-94
15	5	86508131		3	Heater, 6.42 Amp, Use W/208/230 VAC K-90 & K-90E

(1) Used W/Electrically Heated Units Only

(2) BSN 979096; K90, 961976; K90-E, 934742; K94

(3) ASN 979097; K90, 961977; K90-E, 934743; K94

(4) BSN 979096; K90

(5) BSN 979096; K90, 961976; K90-E

**K90 K90E K94**



CONTROL PANEL ELECTRICAL COMPONENTS, USED ON K-90 ASN 897093; K-90E & ASN 886578; K-94 ASN 883812

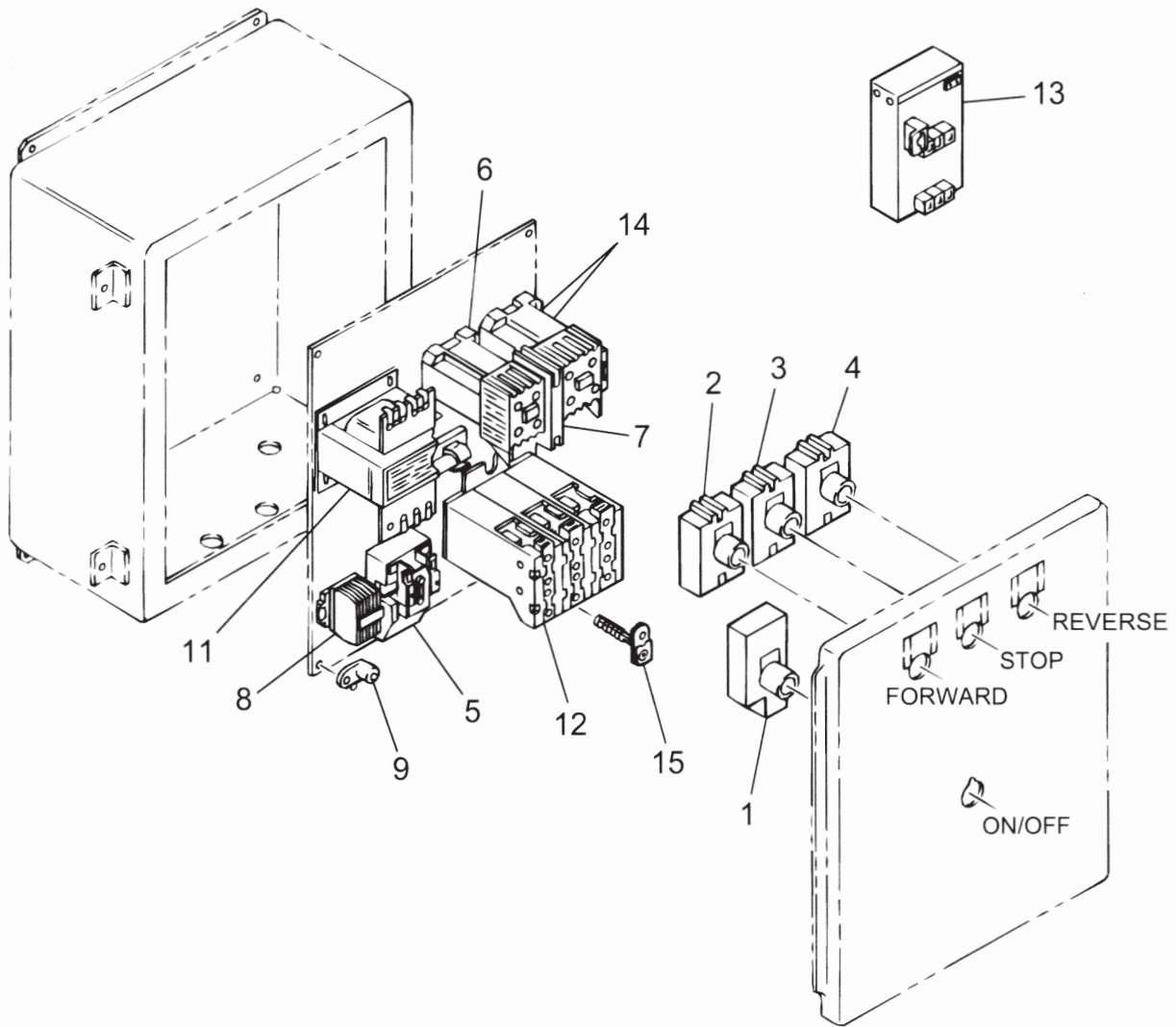

**CONTROL PANEL ELECTRICAL COMPONENTS, USED ON K-90 ASN 897093; K-90E & ASN 886578; K-94 ASN 883812**

REF	FN	PART NUMBER	YR/SN	QTY	DESCRIPTION
15	1	86508132		3	Heater, 8.94 Amp, Use W/208/230 VAC K-94
15	2	86518141		3	Heater, 3.32 Amp, Use W/460 VAC
15	1	86508403		3	Heater, 4.40 Amp, Use W/460 VAC K-94
15	1	86508405		3	Heater, 5.31 Amp, Use W/380 VAC K-94

- (1) BSN 934742; K94
- (2) BSN 979096; K90, 961976; K90-E, 934742; K94

	<b>K90 K90E K94</b>
--	---------------------

UNHEATED DRYER COVER

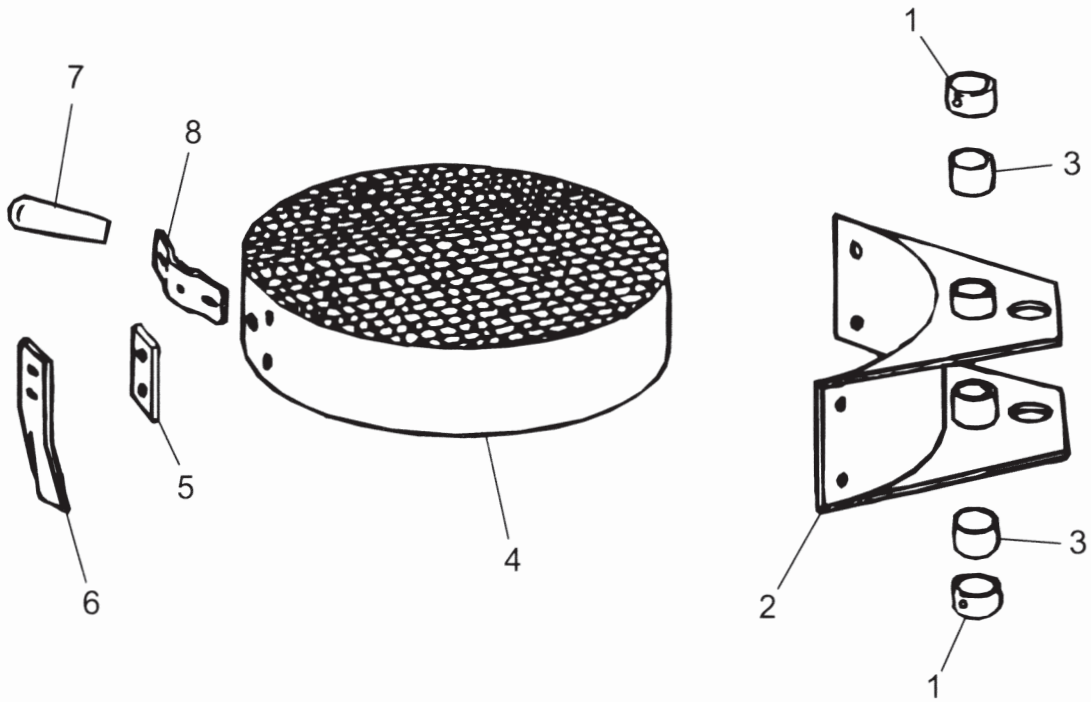

**UNHEATED DRYER COVER**

REF	FN	PART NUMBER	YR/SN	QTY	DESCRIPTION
1		13231		2	Collar, Set
		80429		2	Screw, Set, HS, Cup Pt, 5/16"-18 x 5/16"
2		181256		1	Pivot, Includes: Ref. 3
		271288		4	Screw, Cap, Flg Hd, USR, 5/16"-18 x 5/8"
		145458		4	Nut, Flg, USR, 5/16"-18
3		12431		2	Bushing
4		184251		1	Cover, K-90, K-90E
5		147095		AR	Shim
6		147107		1	Clip, Spring
		9635884		2	Screw, Cap, HH, G5, 5/16"-18 x 1"
		80664		2	Washer, 5/16"
		80681		2	Washer, Lock, 5/16"
7		186610		1	Handle
		280615		1	Bolt, HH, Tap, G5, 1/2"-13 x 2-1/2"
		685896		1	Washer, Nylon, 1/2"
		80679		1	Washer, Lock, 1/2"
		9638005		1	Nut, Jam, G2, 1/2"-13
8		9805627		1	Bracket
		280327		2	Bolt, Carriage, G5, 5/16"-18 x 3/4"
		145458		2	Nut, Flg, USR, 5/16"-18

	<b>K90 K90E K94</b>
--	---------------------



STEAM-HEATED DRYER & COVER

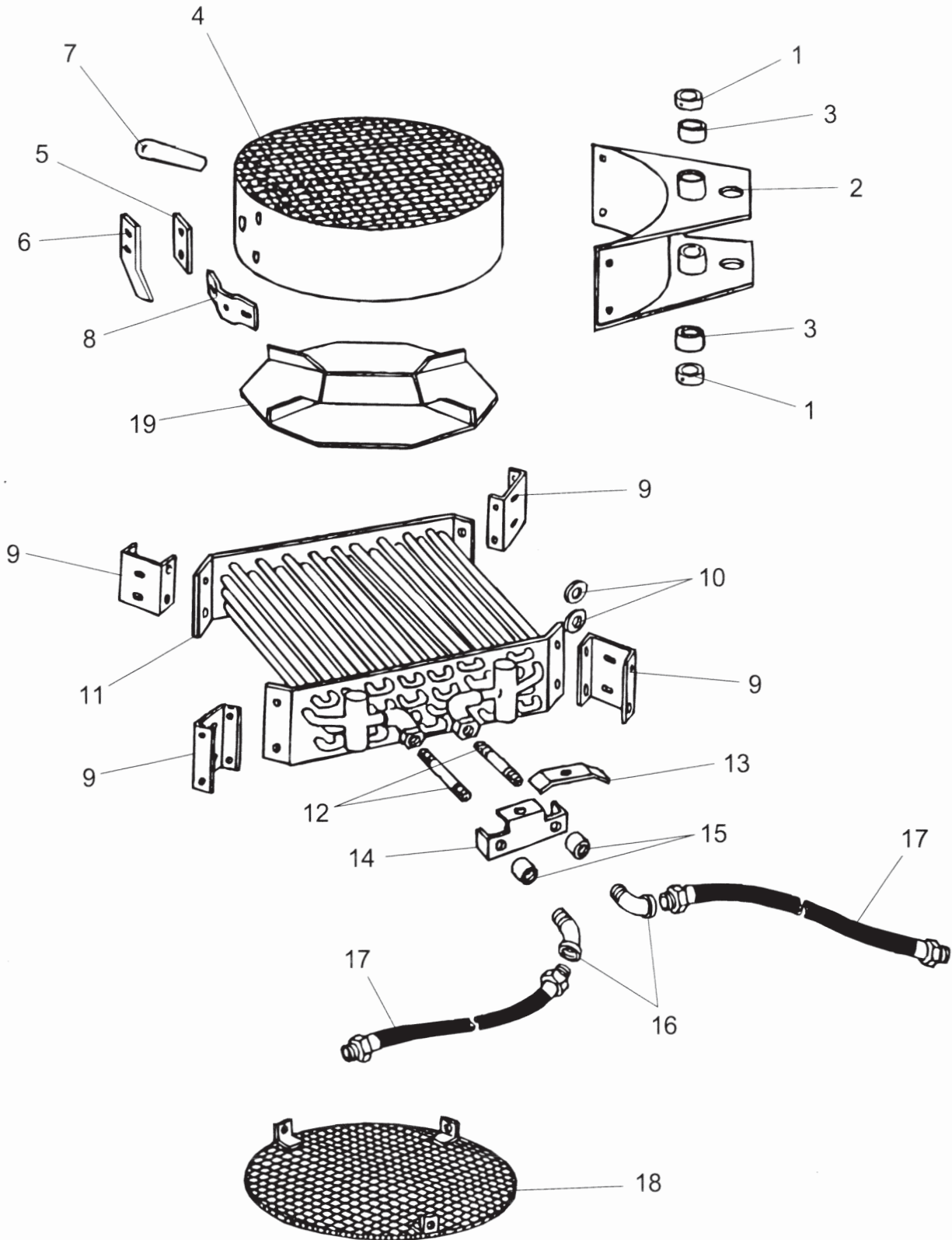

**STEAM-HEATED DRYER & COVER**

REF	FN	PART NUMBER	YR/SN	QTY	DESCRIPTION
1		13231		2	Collar, Set
		80429		2	Screw, Set, HS, Cup Pt, 5/16"-18 x 5/16"
2		181256		1	Pivot, Includes: Ref. 3
		271288		4	Screw, Cap, Flg Hd, USR, 5/16"-18 x 5/8"
		145458		4	Nut, Flg, USR, 5/16"-18
3		12431		2	Bushing
4		184251		1	Cover
5		147095		AR	Shim
6		147107		1	Clip, Spring
		9635884		2	Screw, Cap, HH, G5, 5/16"-18 x 1"
		80664		2	Washer, 5/16"
		80681		2	Washer, Lock, 5/16"
7		186610		1	Handle
		280615		1	Bolt, HH, Tap, G5, 1/2"-13 x 2-1/2"
		685896		1	Washer, Nylon, 1/2"
		80679		1	Washer, Lock, 1/2"
		9638005		1	Nut, Jam, G2, 1/2"-13
8		9805627		1	Bracket
		280327		2	Bolt, Carriage, G5, 5/16"-18 x 3/4"
		145458		2	Nut, Flg, USR, 5/16"-18
9		184240		4	Channel
		523292		8	Screw, Cap, Flg, USR, 1/4"-20 x 3/4"
		523282		8	Nut, Flg, USR, 1/4"-20
10		709157		AR	Spacer
11		147126		1	Condenser
		523292		8	Screw, Cap, Flg, USR, 1/4"-20 x 3/4"
		523282		8	Nut, Flg, USR, 1/4"-20
12		218233		2	Nipple, Pipe, 1/2" x 1-1/2"
13		238831		1	Bracket
14		238830		1	Bracket
		86508775		1	Bolt, Carriage, G5, 3/8"-16 x 1-3/4"
		88902		1	Nut, Lock, GC, 3/8"-16
15		88837		2	Coupling, Pipe, 1/2"
16		88746		2	Elbow, Street, 1/2", 45°
17		101334		2	Hose
18		227450		1	Shield
		677808		3	Screw, Self Tapping, HWH, 1/4"-20 x 5/8"

**K90 K90E K94**

STEAM-HEATED DRYER & COVER

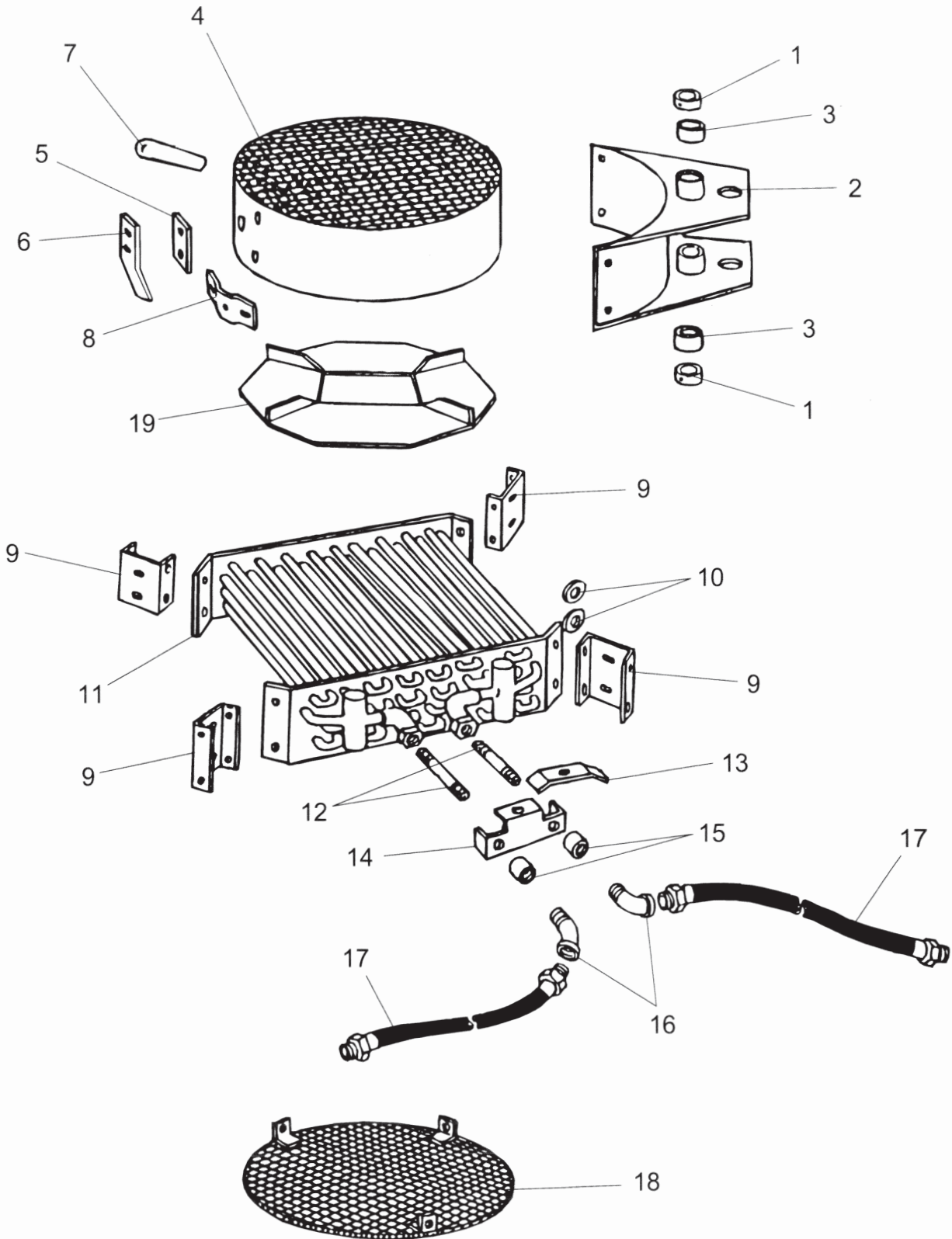

**STEAM-HEATED DRYER & COVER**

REF	FN	PART NUMBER	YR/SN	QTY	DESCRIPTION
19		184238		1	Shield
		677808		2	Screw, Self Tapping, HWH, 1/4"-20 x 5/8"

	<b>K90 K90E K94</b>
--	---------------------



ELECTRICALLY-HEATED DRYER & COVER

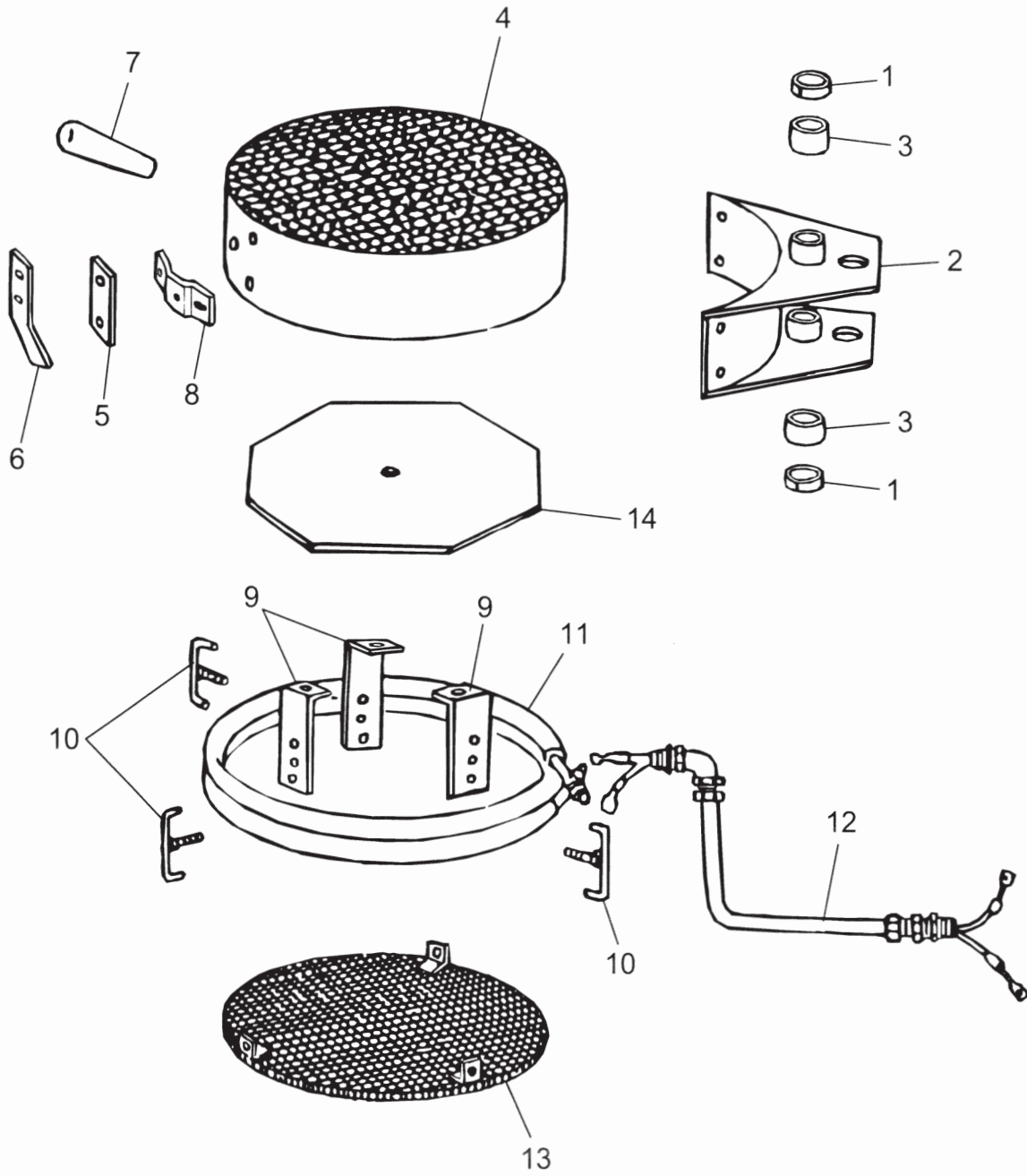

**ELECTRICALLY-HEATED DRYER & COVER**

REF	FN	PART NUMBER	YR/SN	QTY	DESCRIPTION
1		13231		2	Set Collar
		80429		2	Screw, Set, HS, Cup Pt, 5/16"-18 x 5/16"
2		181256		1	Pivot, Includes: Ref. 3
		271288		4	Screw, Cap, Flg Hd, USR, 5/16"-18 x 5/8"
		145458		4	Nut, Flg, USR, 5/16"-18
3		12431		2	Bushing
4		184251		1	Cover
5		147095		AR	Shim
6		147107		1	Clip, Spring
		9635884		4	Screw, Cap, HH, G5, 5/16"-18 x 1"
		80664		2	Washer, 5/16"
		80681		2	Washer, Lock, 5/16"
7		186610		1	Handle
		280615		1	Bolt, HH, Tap, G5, 1/2"-13 x 2-1/2"
		685896		1	Washer, Nylon, 1/2"
		80679			Washer, Lock, 1/2"
		9638005		1	Nut, Jam, G2, 1/2"-13
8		9805627		1	Bracket
		280327		2	Bolt, Carriage, G5, 5/16"-18 x 3/4"
		145458		1	Nut, Flg, USR, 5/16"-18
9		677808		3	HWH, 1/4"-20 x 5/8"
		677808		3	Screw, Self Tapping, HWH, 1/4"-20 x 5/8"
		280129		3	Nut, Lock, Prevailing Torque, G8, 1/4"-20
10		704336		3	U-Clamp
		280129		3	Nut, Lock, Prevailing Torque, G8, 1/4"-20
11		268572		1	Element, Heat, 208 & 240 Volt Rating, 3000/4000 Watts
11		849563		1	Element, Heat, 208 Volt Rating, 4000Watts, K-90
11		268573		1	Element, Heat, 380 Volt Rating, 4000 Watts
11		268574		1	Element, Heat, 480 Volt Rating, 4000 Watts, K90
11		268575		1	Element, Heat, 575 Volt Rating, 4000 Watts
12		263061		1	Conduit & Wire, Heater
13		227450		1	Shield
		677808		3	Screw, Self Tapping, HWH, 1/4"-20 x 5/8"
14		184241		1	Shield
		523291		1	Screw, Cap, Flg, USR, 1/4"-20 x 1/2"
		523282		1	Flg, USR, 1/4"-20

**K90 K90E K94**

ELECTRICALLY-HEATED DRYER & COVER

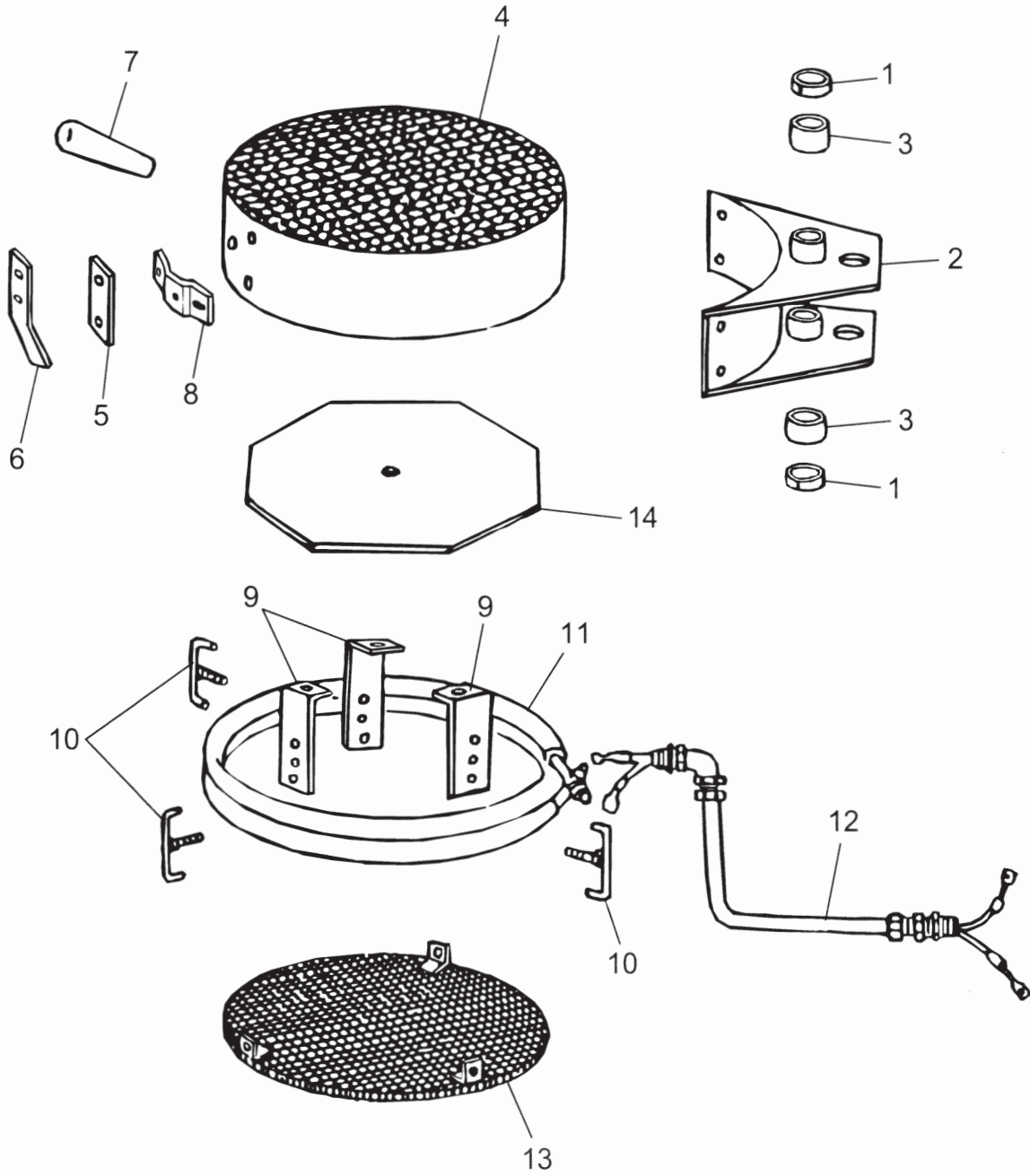

**ELECTRICALLY-HEATED DRYER & COVER**

REF	FN	PART NUMBER	YR/SN	QTY	DESCRIPTION
-----	----	-------------	-------	-----	-------------

		677808		3	Screw, Self Tapping, HWH, 1/4"-20 x 5/8"
--	--	--------	--	---	--

	<b>K90 K90E K94</b>
--	---------------------



DECALS

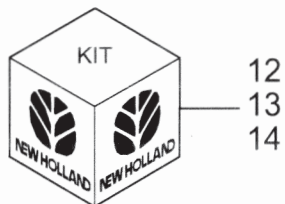
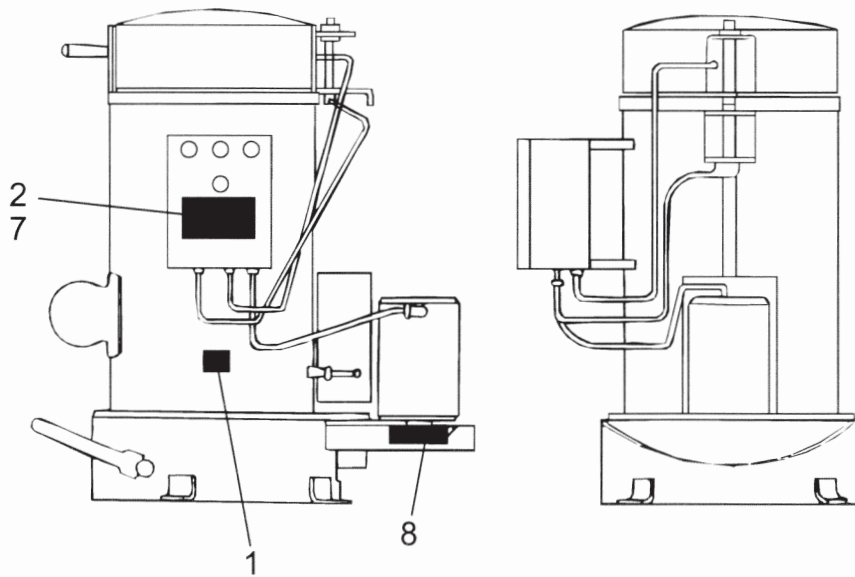
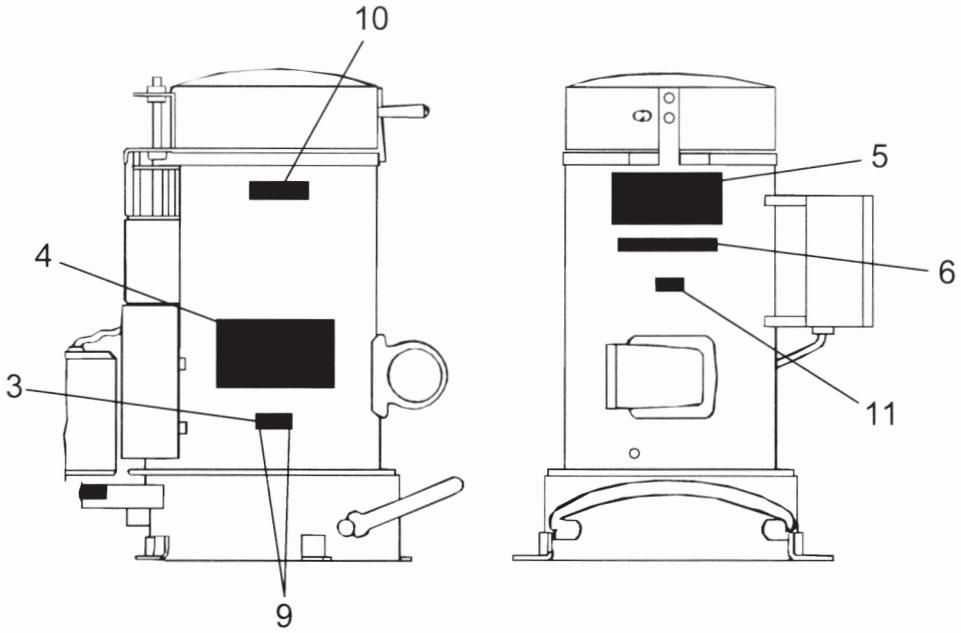

**DECALS**

REF	FN	PART NUMBER	YR/SN	QTY	DESCRIPTION
1		145067		1	Sign, Patent
2		782166		1	Sign, Warning, Inside Cover
3		NSS		1	Plate, Model/Serial
4		855048		1	Sign, Information, K-90
4		855049		1	Sign, Information, K-90E
4		9802899		1	Sign, Information, K-94
5		855053		1	Sign, Caution
6		388435		1	Sign, NH Yellow 16
7		719836		1	Sign, Attention
8		9609360		2	Sign, Attention
9		86598785		2	Screw, Self-Tapping, Rd Hd, Stainless Steel, #4 x 1/4"
10		850252		1	Sign, Reconditioned
11		719740		1	Label, Underwriters
12		855020		1	Kit, Decal, K-90 Includes: Ref. 1, 2, 4 - 8
13		855023		1	Kit, Decal, K-90E Includes: Ref. 1, 2, 4 - 8
14		9804035		1	Kit, Decal, K-94 Includes: Ref. 1, 2, 4 - 8

	<b>K90 K90E K94</b>
--	---------------------

INDEX - INDICE - INDEX - ZAHLENVERZEICHNIS - INDICE - INDICE - INHOLD - INHOUD

Number	Figure	Sequence	Ref.	Number	Figure	Sequence	Ref.
{100192}	02.01		2	{181256}	03.06		2
{100194}	02.01		2	{181259}	03.01		44
{100195}	02.01		2	{181264}	03.01		46
{101179}	02.01		2	{184238}	03.05		19
{101180}	02.01		2	{184240}	03.05		9
{101183}	02.01		2	{184241}	03.06		14
{101184}	02.01		2	{184246}	03.01		26
{101185}	02.01		2	{184249}	03.01		30
{101208}	02.01		6	{184251}	03.04		4
{101214}	02.01		5		03.05		4
{101238}	02.01		32		03.06		4
	03.01		32	{184257}	03.01		18
{101245}	02.01		23	{184272}	03.01		39
	03.01		25	{184354}	03.01		47
{101248}	02.01		36	{196029}	03.01		1
	03.01		36	{204815}	02.01		50
{101253}	02.01		16	{216740}	03.01		38
	03.01		17	{218522}	02.01		18
{101257}	02.01		11		03.01		19
{101258}	02.01		9	{227450}	03.05		18
{101259}	02.01		8		03.06		13
{101260}	02.01		12	{238830}	03.05		14
{101262}	02.01		22	{242214}	02.01		41
	03.01		23	{242215}	03.01		41
{101263}	02.01		7	{242216}	02.01		41
{101266}	02.01		19	{242218}	02.01		41
{101268}	02.01		47	{242219}	03.01		41
	03.01		50	{242980}	02.01		43
{101269}	02.01		29		03.01		43
{101270}	02.01		26	{254321}	02.03	1	8
	03.01		27		02.03	2	8
{101271}	02.01		33		03.03	1	8
	03.01		33		03.03	2	8
{101272}	02.01		17	{254322}	02.01		13
{101304}	02.01		48	{254323}	03.01		14
	03.01		51	{263049}	02.06		11
{101319}	02.02		9	{263050}	02.06		11
	03.02		9	{263051}	02.06		11
{101334}	02.05		13	{263054}	02.06		11
	03.05		17	{263061}	02.02		8
{13231}	02.04		1		02.06		12
	02.05		1		03.02		8
	02.06		1		03.06		12
	03.04		1	{268572}	03.06		11
	03.05		1	{268573}	03.06		11
	03.06		1	{268574}	03.06		11
{143274}	02.01		27	{268575}	03.06		11
	03.01		28	{280528}	02.03	1	
{145067}	02.07		2		02.03	2	
	03.07		1		03.03	1	
{145300}	01.02		14		03.03	2	
	03.02		10	{52706}	03.01		22
{147084}	02.04		4	{6132}	02.01		35
	02.05		4		03.01		35
	02.06		4	{627865}	01.02		19
{147087}	02.04		2	{636717}	03.01		14
	02.05		2	{680133}	02.01		45
	02.06		2		03.01		45
{147092}	02.01		46	{693949}	02.04		2
{147097}	02.01		1		02.05		2
{147098}	02.01		44		02.06		2
{147100}	02.01		40	{693953}	02.01		46
	03.01		40	{699312}	01.02		16
{147102}	02.01		34	{699767}	02.01		49
	03.01		34		03.01		52
{147104}	02.01		25	{700283}	02.01		41
{147107}	02.04		6	{700284}	03.01		41
	02.05		6	{704334}	02.06		9
	02.06		6	{704336}	02.06		10
	03.04		6		03.06		10
	03.05		6	{709157}	02.05		9
	03.06		6		03.05		10
{147111}	02.01		39	{719729}	03.01		4
{147126}	02.05		16	{719730}	03.01		6
	03.05		11	{719732}	03.01		3
{147131}	02.06		14	{719740}	02.07		9
{147138}	02.05		14		03.07		11
	02.06		13	{719742}	02.01		3
{147231}	03.01		7	{719744}	03.01		
{147236}	03.01		20	{719836}	02.07		3
{181256}	03.04		2		03.07		7
	03.05		2	{782166}	02.07		5

INDEX - INDICE - INDEX - ZAHLENVERZEICHNIS - INDICE - INDICE - INHOLD - INHOUD

Number	Figure	Sequence	Ref.	Number	Figure	Sequence	Ref.
{782166}	03.07		2	{855070}	03.02		4
{786634}	01.03		7	{855142}	01.02		
{786642}	01.02		1		01.02		
{786647}	01.02		18		01.02		
{786650}	01.02		11	{86507411}	02.03	1	13
{786652}	01.02		17		03.03	1	13
{786653}	01.02		27	{86507412}	02.03	1	13
{786663}	01.02		9		03.03	1	13
{786682}	01.01		9	{86508116}	02.03	2	7
{786684}	01.02		7		03.03	2	7
{786685}	01.02		12	{86508117}	02.03	2	6
{786686}	01.02		15		03.03	2	6
{786687}	01.01		13	{86508118}	02.03	2	12
{786690}	01.02		4		03.03	2	12
{786691}	01.02		8	{86508125}	02.03	2	14
{786694}	01.02		5		03.03	2	14
{788386}	02.01			{86508128}	02.03	2	15
	03.01			{86508129}	03.03	2	15
{788387}	02.01		20	{86508130}	02.03	2	15
{798105}	01.02		6		03.03	2	15
{798106}	01.02		22*	{86508131}	03.03	2	15
{802718}	01.01		1	{86508132}	03.03	2	15
{802719}	01.01		1	{86508402}	02.03	2	15
{802720}	01.01		1	{86508403}	03.03	2	15
{803042}	01.01		1	{86508405}	03.03	2	15
{80443}	01.01		3	{86518141}	03.03	2	15
{849562}	02.06		11	{86529635}	02.03	2	16
{849563}	03.06		11		03.03	1	14
{849647}	01.03		4	{86529636}	02.02		11
{849648}	01.03		3		02.03	1	14
{849887}	02.01		37		03.02		12
{849889}	03.01		37	{86545169}	02.03	2	15
{850252}	02.07		8	{86545170}	02.03	2	15
	03.07		10	{86586797}	02.03	2	6
{850902}	01.02		26		03.03	2	6
{855017}	02.07		12		03.03	2	7
{855020}	03.07		12	{86586798}	02.03	2	7
{855023}	03.07		13	{86586799}	02.03	2	14
{855042}	02.03	1	11		03.03	2	14
	02.03	2	11	{86586800}	02.03	2	12
	03.03	1	11	{86586801}	02.03	2	12
	03.03	2	11		03.03	2	12
{855043}	02.03	1	11	{86586802}	03.03	2	12
	02.03	2	11	{87476}	03.01		
	03.03	1		{87741}	02.05		10
	03.03	2	11	{88402}	03.01		
{855047}	02.07		7	{885142}	01.02		
{855048}	03.07		4	{9601493}	02.01		24
{855049}	03.07		4		03.01		24
{855050}	02.03	1	6	{9602072}	03.01		2
	03.03	1	6	{9602073}	03.01		2
{855051}	02.03	1	7	{9602074}	03.01		2
	03.03	1	7	{9602075}	03.01		2
{855052}	02.03	1	5	{9602076}	03.01		2
	02.03	2	5	{9602077}	03.01		2
	03.03	1	5	{9602078}	03.01		2
	03.03	2	5	{9602079}	03.01		2
{855053}	02.07		1	{9609360}	02.07		10
	03.07		5		03.07		8
{855054}	02.02		7	{9609479}	02.02		6
	03.02		7		03.02		6
{855056}	02.02		3	{9614995}	02.02		6
	03.02		3	{9616651}	02.01		2
{855058}	02.02		1	{9621678}	02.03	1	12
	03.02		1		03.03	1	12
{855061}	02.03	1	12	{9621926}	01.02		25
{855062}	03.03	1	12	{9621927}	01.02		
{855063}	03.03	1	12	{9802886}	03.01		14
{855064}	03.03	1	12	{9802887}	03.01		41
{855066}	02.03	1	2	{9802888}	03.01		41
	02.03	2	2	{9802889}	03.01		41
	03.03	1	2	{9802891}	03.01		37
	03.03	2	2	{9802899}	03.07		4
{855067}	02.03	1	3	{9802901}	03.01		44
	02.03	2	3	{9802903}	03.01		43
	03.03	1	3	{9802904}	03.01		5
	03.03	2	3	{9803999}	03.01		2
{855068}	02.03	1	4	{9804000}	03.01		2
	02.03	2	4	{9804001}	03.01		2
	03.03	1	4	{9804002}	03.01		2
	03.03	2	4	{9804003}	03.01		2
{855070}	02.02		4	{9804004}	03.01		2



INDEX - INDICE - INDEX - ZAHLENVERZEICHNIS - INDICE - INDICE - INHOLD - INHOUD

Number	Figure	Sequence	Ref.	Number	Figure	Sequence	Ref.
{9804005}	03.01		2	186610	03.05		7
{9804006}	03.01		2		03.06		7
{9804035}	03.07		14	207705	02.05		15
{9804202}	03.03	1	12	218233	03.05		12
{9805627}	02.04		8	238831	03.05		13
	02.05		8	242217	03.01		41
	02.06		8	262635	02.03	1	
	03.04		8		02.03	2	
	03.05		8		03.03	1	
	03.06		8		03.03	2	
{9806731}	01.02		21	263117	01.02		28
{9809333}	03.01		2	26402	01.01		4
{9809334}	03.01		2	26650	02.01		
{9809335}	03.01		2	271288	01.02		
{9809336}	03.01		2		02.04		
{9849153}	01.01		6		02.05		
{9862265}	02.02		10		02.05		
	03.02		11		02.06		
{9862726}	03.01		2		02.06		
{9862727}	03.01		2		03.04		
{9862728}	03.01		2		03.05		
{9862729}	03.01		2		03.06		
{9862730}	03.01		2	27767	02.01		14
{9862731}	03.01		2		03.01		15
{9862732}	03.01		2	280129	01.02		
{9862747}	03.01		2		02.06		
{9863576}	02.03	2	17		03.06		
{9863898}	02.01		2		03.06		
{9863899}	03.01		2	280237	01.02		
	03.01		2	280251	01.01		
{9863900}	03.01		2		01.01		
	03.01		2	280327	02.04		
{9863901}	03.01		2		02.05		
{9863902}	03.01		2		02.06		
101242	02.01		28		03.04		
101367	02.01		4		03.05		
103989	01.02		13		03.06		
12431	02.04		3	280384	01.02		
	02.05		3		01.02		
	02.06		3	280431	02.05		
	03.04		3		03.01		
	03.05		3	280519	02.01		
	03.06		3		02.01		
133587	02.01		2		03.01		
141360	02.03	1	9		03.01		
	02.03	2	9	280580	02.01		
	03.03	1	9		03.01		
	03.03	2	9		03.01		
145458	02.04				03.01		
	02.04				03.01		
	02.05			280615	01.02		
	02.05				02.04		
	02.06				02.05		
	02.06				02.06		
	02.06				03.04		
	02.06				03.05		
	03.04				03.06		
	03.04			280626	02.05		
	03.05			281020	02.03	1	
	03.05				02.03	1	
	03.06				02.03	2	
	03.06				02.03	2	
147095	02.04		5		03.03	1	
	02.05		5		03.03	1	
	02.06		5		03.03	2	
	03.04		5		03.03	2	
	03.05		5	281076	02.03	1	
	03.06		5		02.03	2	
147108	02.01		38		03.03	1	
147212	03.01		8		03.03	2	
147213	03.01		10	28581	02.01		21
147214	03.01		9	28656	02.01		10
147216	03.01		12	289054	01.01		14
147223	03.01		21	34235	02.01		15
147229	03.01		13		03.01		16
147233	03.01			388435	02.07		4
184254	03.01		29		03.07		6
186610	01.02		2	39122	01.01		15
	02.04		7	42019	01.01		11
	02.05		7	443898	01.01		5
	02.06		7	46431	01.02		
	03.04		7	516579	01.02		3

INDEX - INDICE - INDEX - ZAHLENVERZEICHNIS - INDICE - INDICE - INHOLD - INHOUD

Number	Figure	Sequence	Ref.	Number	Figure	Sequence	Ref.
523282	01.02			80681	02.01		
	01.02				02.01		
	02.05				02.01		
	02.06				02.04		
	03.05				02.05		
	03.05				02.06		
	03.06				03.01		
523291	01.02				03.01		
	01.02				03.01		
	02.06				03.01		
	03.06				03.01		
523292	02.05				03.04		
	03.05				03.05		
	03.05				03.06		
593526	02.03	1	10	80682	02.02		
	02.03	2	10		03.02		
	03.03	1	10	80684	01.02		
	03.03	2	10		01.02		
602997	01.02		24	80701	02.02		
627868	01.02		23		03.02		
676397	02.01		31	80702	01.02		
	03.01		31		02.01		
677808	01.02				02.05		
	01.02				02.05		
	02.05			80707	03.01		
	02.06			80710	01.02		
	02.06				02.01		
	03.05			80755	03.01		
	03.05				02.01		
	03.06				02.01		
	03.06				03.01		
	03.06			80801	03.01		
	03.06		9	81761	02.01		
685896	01.02				03.01		
	02.04			84461	01.02		
	02.05			84821	01.02		
	02.06			84859	02.01		
	03.04			851401	01.03		2
	03.05			851512	01.02		10
	03.06			855055	02.02		5
690341	02.01				03.02		5
	03.01			855069	02.03	1	1
703018	01.01		12		02.03	2	1
770983	02.05				03.03	1	1
7770	02.02				03.03	2	1
	03.02			86508775	03.05		
80245	02.01			86511189	01.02		
	03.01			86511449	01.02		
80426	02.01			86511908	01.02		
	03.01			86512813	02.01		42
80429	02.04				03.01		42
	02.05			86544338	01.02		
	02.06				02.03	1	
	03.04				02.03	2	
	03.05				03.03	1	
	03.06				03.03	2	
80664	01.02			86598785	03.07		9
	01.02			86624371	02.03	2	13
	02.01				03.03	2	13
	02.01			86624372	02.03	2	13
	02.04				03.03	2	13
	02.05			86624388	03.02		
	02.06			87267	01.02		
	03.01			87304	01.02		
	03.01				01.02		
	03.04			87361	01.01		10
	03.05			87362	02.01		
	03.06				03.01		
80679	02.04			87366	01.02		20
	02.05			87414	02.01		
	02.06			87569	03.01		
	03.01				03.01		
	03.04			87653	02.01		
	03.05				03.01		
	03.06			87654	02.03	1	
80680	01.02				02.03	2	
	02.01				03.03	1	
	03.01				03.03	2	
80681	01.02			87718	02.01		30
	01.02				03.01		
	02.01				03.01		

INDEX - INDICE - INDEX - ZAHLENVERZEICHNIS - INDICE - INDICE - INHOLD - INHOUD

Number	Figure	Sequence	Ref.	Number	Figure	Sequence	Ref.
87718	03.01		48				
87812	02.01						
	03.01						
87936	02.01						
	03.01						
87949	02.01						
	03.01						
88206	01.02						
	02.01						
	03.01						
88363	02.01						
	03.01						
88458	01.02						
88528	02.01						
	03.01						
88565	02.01						
	03.01						
88574	02.01						
	03.01						
88746	02.05		12				
	03.05		16				
88837	02.05		11				
	03.05		15				
88872	01.01		8				
88902	01.02						
	02.01						
	02.01						
	02.05						
	03.01						
	03.01						
	03.05						
88992	02.01						
	03.01						
	03.01						
91932	02.01						
	03.01						
9617878	01.01		7				
9617935	03.01		11				
9628503	02.01						
	02.05						
	03.01						
9635082	01.02						
	01.02						
	02.01						
	02.01						
	02.01						
	03.01						
9635884	02.01						
	02.04						
	02.05						
	02.06						
	03.01						
	03.04						
	03.05						
	03.06						
9638005	01.02						
	02.01						
	02.04						
	02.05						
	02.05						
	02.06						
	03.01						
	03.01		49				
	03.04						
	03.05						
	03.06						
9706689	02.01						
9706729	02.01						
9707580	02.02						
	03.02						
9849151	01.01		2				
NSS	01.03		1				
	01.03		5				
	01.03		6				
	02.02		2				
	02.07		11				
	02.07		6				
	03.02		2				
	03.07		3				







TRUSTED NAMES IN EQUIPMENT

